

**SERVICE MANUAL
&
PARTS LIST**

**MODEL: 5270QDC
(For Europe only)**

INDEX

What to do when..... 1 to 3

CHANGING EXTERNAL PARTS

FACE COVER4
FREE ARM COVER5
FRONT COVER6 to 7
REAR COVER.....8

MECHANICAL ADJUSTMENT

PRESSER BAR HEIGHT9
NEEDLE DROP POSITION.....10
ADJUSTMENT OF HOOK TIMING11
ADJUSTMENT OF NEEDLE BAR HEIGHT12
CLEARANCE BETWEEN NEEDLE AND TIP OF THE ROTARY HOOK13
FEED DOG HEIGHT14
FEED DOG ADJUSTMENT.....15
TOP TENSION16
STRETCH STITCH FEED BALANCE17
ADJUSTING BUTTONHOLE LEVER POSITION.....18
REPLACING AND ADJUSTING THE PRESSER FOOT LIFTER SWITCH UNIT19
REPLACING AND ADJUSTING THE KNEE LIFTER WIRE UNIT20 to 21
REPLACING AND ADJUSTING THE NEEDLE THREADER HOLDER.....22 to 23
THREAD CUTTER24

SELF-DIAGNOSTIC TEST

SELF-DIAGNOSTIC TEST25 to 30
TO DISPLAY THE VERSION OF THE PROGRAM.....30

REPLACING THE ELECTRONIC COMPONENTS

PRINTED CIRCUIT BOARD A CONNECTION31
PRINTED CIRCUIT BOARD A32
DRIVING MOTOR33
SWITCHING REGULATOR UNIT.....34
CLEANING AREA OF THREAD CUTTER AND LOWER SHAFT GEAR.....35
KEY POSITION ADJUSTMENT36
TOUCH PANEL KEY POSITION ADJUSTMENT GUIDE PRINTED
THE ILLUSTRATION (ACTUAL SIZE)37

PARTS LIST38 to 53

WHAT TO DO WHEN

Condition	Cause	How to fix	Reference
1. Skipping Stitches	<ol style="list-style-type: none"> 1. Needle is not inserted properly. 2. Needle is bent or worn. 3. Incorrectly threaded. 4. Needle or thread are inappropriate for the fabric being sewn. 5. Sewing on stretch fabric. 6. Inappropriate needle bar height. 7. Inappropriate needle to hook timing. 8. Inappropriate needle to hook clearance. 	<p>Insert the needle properly.</p> <p>Change the needle.</p> <p>Rethread.</p> <p>Use the recommended sewing needle and thread.</p> <p>Use a HA x #11 blue tip needle.</p> <p>See mechanical adjustment "Adjustment of needle bar height".</p> <p>See mechanical adjustment "Adjustment of hook timing".</p> <p>See mechanical adjustment "Clearance between needle and tip of the rotary hook".</p>	<p>P. 12</p> <p>P. 11</p> <p>P. 13</p>
2. Fabric not moving	<ol style="list-style-type: none"> 1. Incorrect feed dog height. 2. Feed dog is in down position. 3. Thread on bottom side of fabric is jammed up. 	<p>See mechanical adjustment "Feed dog height".</p> <p>Raise the feed dog.</p> <p>Make sure to bring both needle and bobbin threads under the foot when start sewing.</p>	<p>P. 14</p>

WHAT TO DO WHEN

Condition	Cause	How to Fix	Reference
3. Breaking upper thread.	<ol style="list-style-type: none">1. Initial sewing speed is too fast.2. Thread path is incorrect.3. Needle is bent or dull.4. Top tension is too strong.5. Needle size is inappropriate for fabric.6. Needle eye is worn.7. Needle hole in needle plate is worn or burred.	<p>Start with medium speed.</p> <p>Use the proper thread path.</p> <p>Replace with a new needle.</p> <p>Adjust top tension correctly.</p> <p>Use appropriate needle for fabric and thread in use.</p> <p>Change the needle.</p> <p>Repair the hole or replace the needle plate.</p>	P. 16
4. Breaking bobbin thread.	<ol style="list-style-type: none">1. Bobbin holder is incorrectly threaded.2. Too much thread is wound on the bobbin.3. Lint is stuck inside the bobbin holder.4. Thread quality is too low.5. Thread is jamming around the bobbin holder.	<p>Set the bobbin thread correctly.</p> <p>Adjust the position of bobbin winder stopper.</p> <p>Clean the bobbin holder.</p> <p>Change to a high quality sewing thread.</p> <p>Clear out the jamming thread.</p>	
5. Needle breaks	<ol style="list-style-type: none">1. Needle is hitting the needle plate.2. Needle is bent or worn.3. Needle is hitting the hook.4. Fabric is being pulled too strongly while sewing.	<p>See mechanical adjustment "Needle drop position".</p> <p>Change the needle.</p> <p>See mechanical adjustment "Clearance between needle and tip of the rotary hook".</p> <p>Guide the fabric gently while sewing.</p>	P. 10 P. 13

WHAT TO DO WHEN

Condition	Cause	How to fix	Reference
6. Noisy operation	<ol style="list-style-type: none"> 1. Backlash between hook gear and lower shaft gear is too great. 2. Lower shaft gear is loose. 3. Inappropriate belt tension. 4. Not enough oil. 5. Upper shaft gear is loose. 	<p>Eliminate the backlash.</p> <p>Eliminate the looseness.</p> <p>See part removal and replacement "Driving motor (DC motor)".</p> <p>Oil all moving parts.</p> <p>Eliminate the looseness.</p>	P. 33
7. Deformation pattern	<ol style="list-style-type: none"> 1. Inappropriate feed balance. 2. Top tension is too strong. 	<p>Adjust the feed balancing dial.</p> <p>See mechanical adjustment "Top tension".</p>	<p>P. 17</p> <p>P. 16</p>

CHANGING EXTERNAL PARTS

FACE COVER

To remove:

1. Remove the setscrews (2 pcs.) ① and remove the face cover ②.

To attach:

2. Follow the above procedures in reverse.

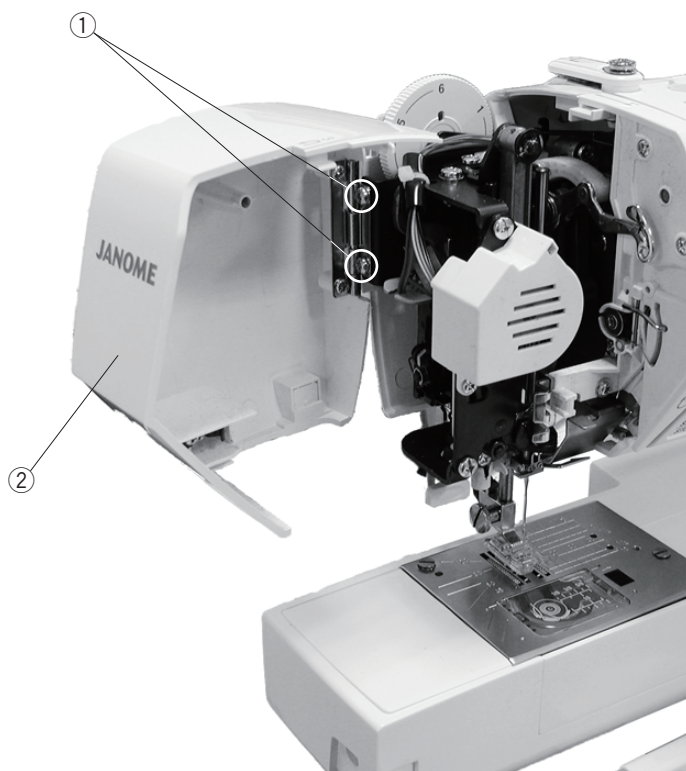

CHANGING EXTERNAL PARTS

FREE ARM COVER

To remove:

1. Remove the setscrews ① (2 pcs.). Move the free arm cover ② to the left.
Remove the free arm cover.

To attach:

2. Follow the above procedures in reverse.

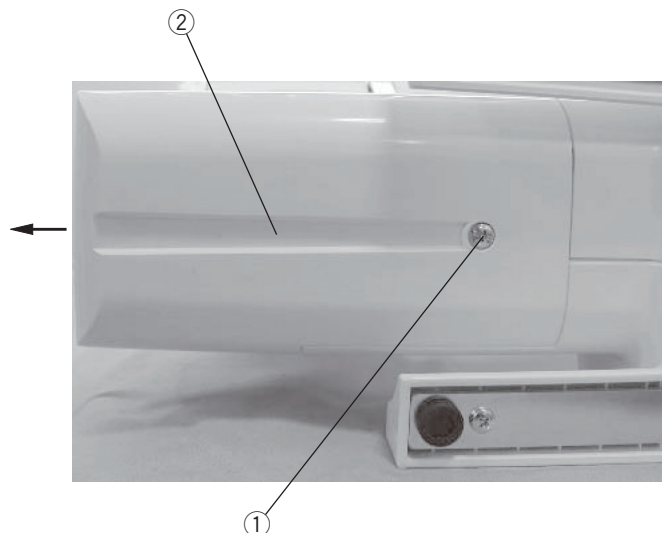
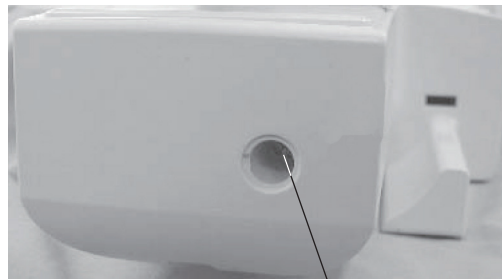

CHANGING EXTERNAL PARTS

FRONT COVER (1)

To remove:

1. Remove the face cover and free arm cover (see pages 4 and 5).
2. Remove the setscrews A ① (2 pcs.).
3. Remove the setscrews B ② (2 pcs.) and bed cover ③.
4. Remove the setscrew C ④.
5. Remove the setscrews D ⑤ (2 pcs.).
6. Loosen the setscrew E ⑥.

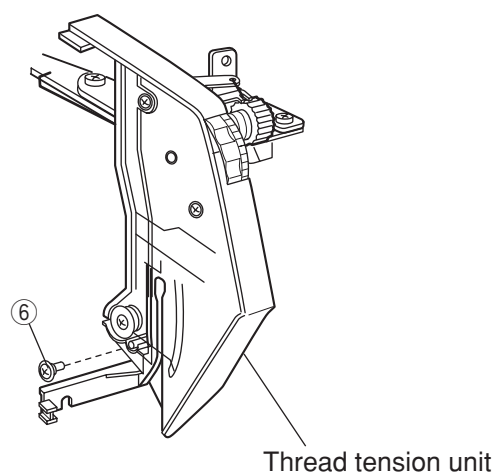
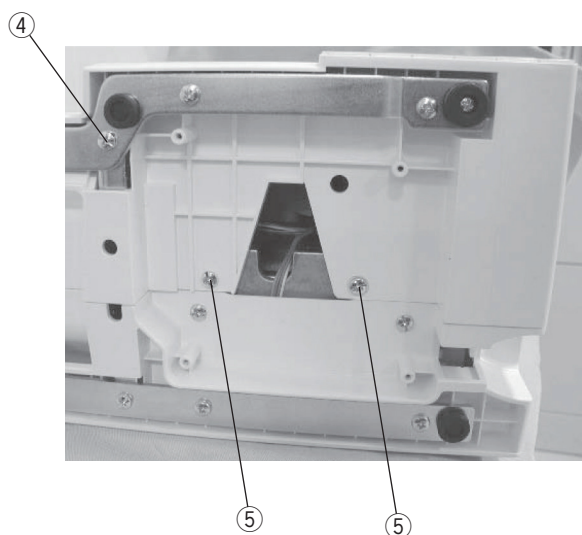
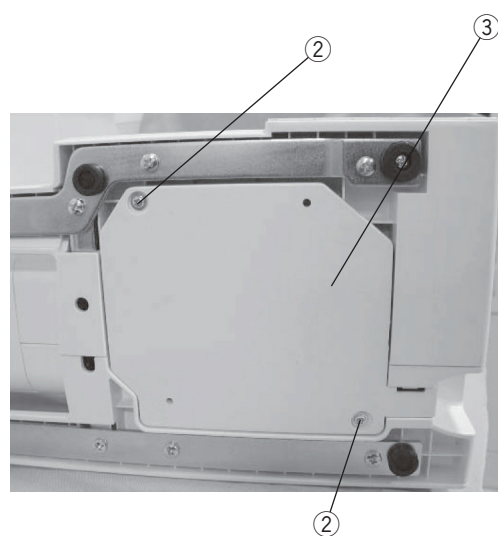

CHANGING EXTERNAL PARTS

FRONT COVER (2)

7. Disengage the front cover and rear cover hooks.
8. Disconnect all the connectors from the circuit board A.

NOTE:

Do not disconnect the connectors by pulling on cord.

To disconnect, grasp the connector, not the cord.

9. Remove the front cover.

To attach:

10. Follow the above procedures in reverse.

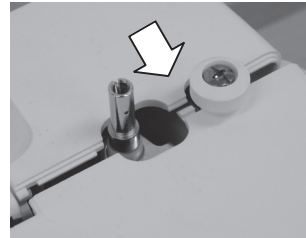
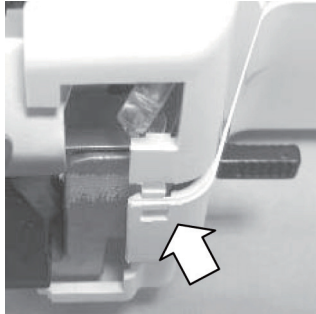

CHANGING EXTERNAL PARTS

REAR COVER

To remove:

1. Remove the face cover and free arm cover (see pages 4 and 5).
2. Remove the setscrews A ① (2 pcs.).
3. Remove the setscrews B ② (3 pcs.).
4. Remove the setscrews C ③ (2 pcs.) and bed cover ④.
5. Remove the setscrews D ⑤ (2 pcs.).
6. Remove the setscrew E ⑥. Remove the rear cover.

To attach:

7. Follow the above procedures in reverse.

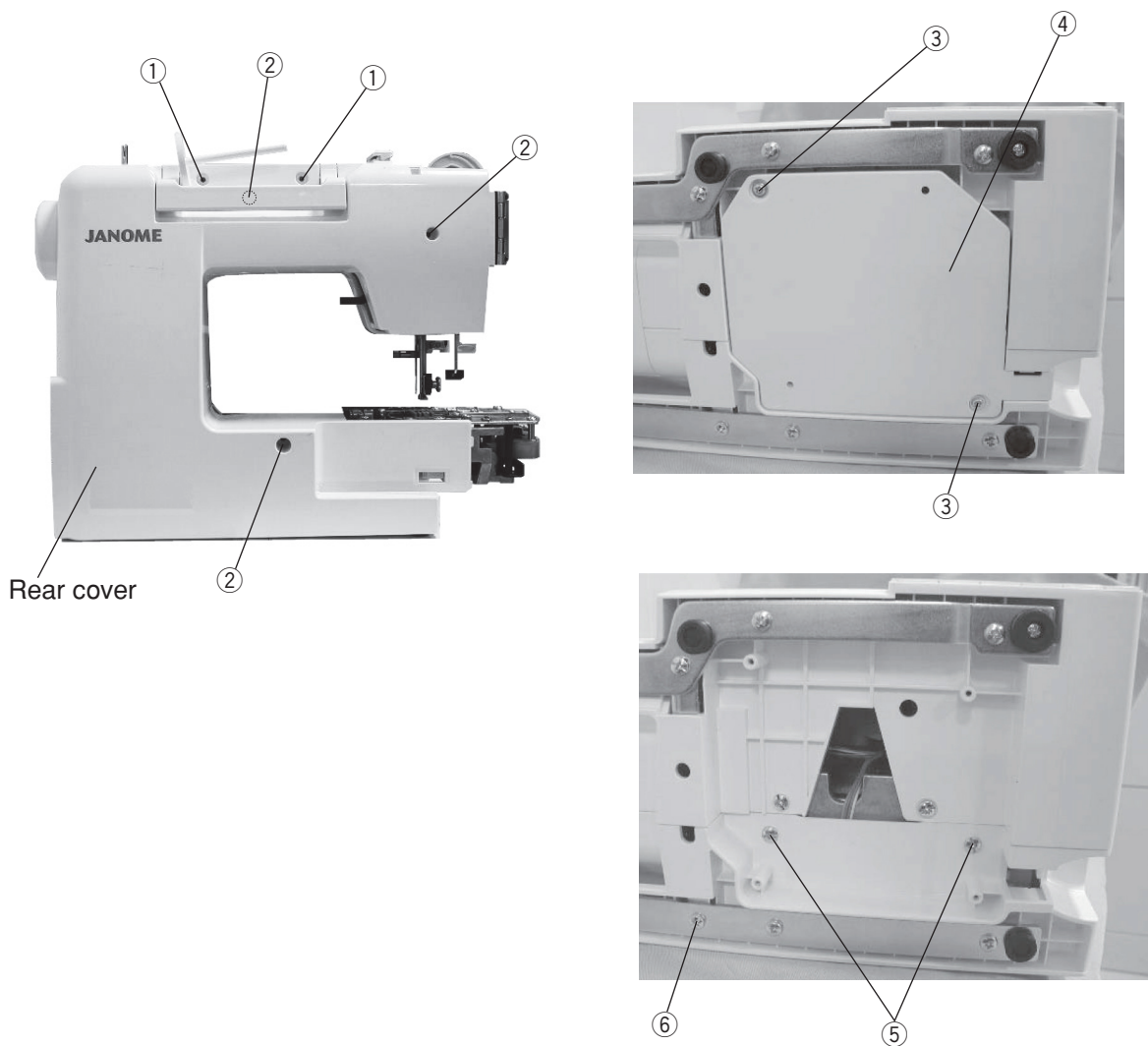

MECHANICAL ADJUSTMENT

PRESSER BAR HEIGHT

The distance between the bottom of the presser foot in up position and the needle plate should be 6.0 mm.

1. Remove the face cover and needle.
2. Lower the feed dog below the needle plate.
Place a block 6 mm thick under the presser foot and lower the presser foot lifter ②.
3. Loosen the setscrew ①. Raise the presser foot lifter and tighten the setscrew ① firmly.
Attach the needle and face plate.

NOTE:

Make sure that the presser foot should be parallel to the feed dog slots ③ in the needle plate.

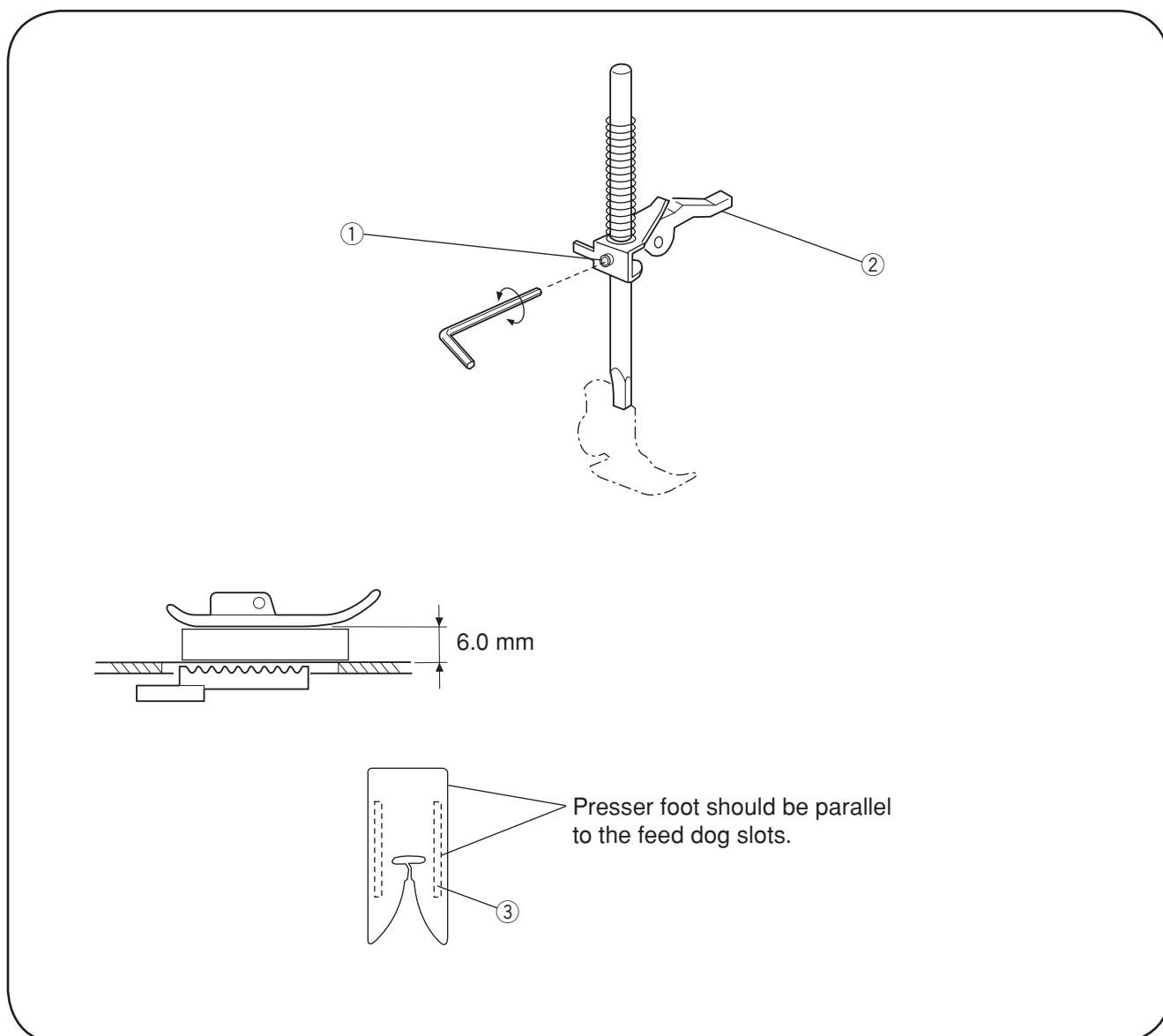

MECHANICAL ADJUSTMENT

NEEDLE DROP POSITION

Set the stitch pattern to “ \oplus ”. The standard needle drop position should be at center of the needle plate hole ①. Select zigzag stitch “ \sim ”, and set the stitch width at “7.0”. The clearance between the needle and the edge of the needle plate hole should be at least 0.2 mm on either side. If not, adjust as follows:

1. Turn the power switch off. Remove the face cover (see page 4).
2. Loosen the hexagonal socket screw 3x4 ②. Adjust the needle drop position by turning the eccentric pin. The direction of eccentric pin should be as shown in FIG. 1.
3. Attach the face cover.

NOTE:

Check the hook timing after this adjustment.

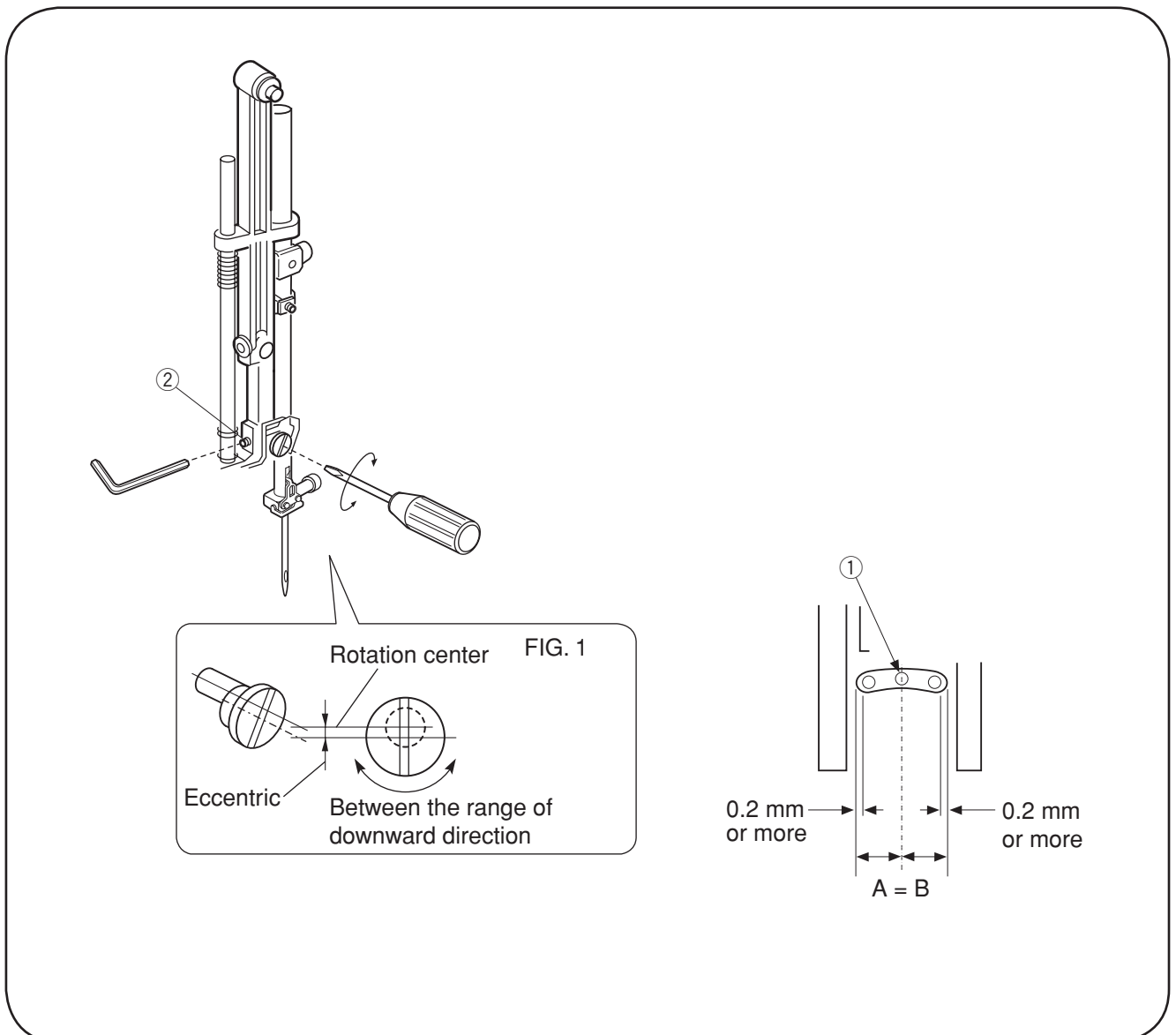

MECHANICAL ADJUSTMENT

ADJUSTMENT OF HOOK TIMING

The amount of ascending travel of the needle bar from its lowest position to the position () where the tip of the rotary hook exactly meets the right side of the needle should be 3.25 to 3.55 mm.

1. Remove the setscrews (2 pcs.) on the needle plate, the needle plate and the bobbin holder.
2. Remove the free arm cover (see page 5).
3. Turn the power switch on.
4. Select the pattern  (left position). Set the zigzag width at 0.
Turn the handwheel toward you to lower the needle at its lowest position.
5. Loosen the hexagonal socket screw (2 pcs.).
6. Move the needle bar 3.25 to 3.55 mm from the lowest position.
7. Turn the lower shaft gear until the tip of hook meets the right side of the needle while holding the handwheel.
8. Tighten the hexagonal socket screw (2 pcs.).
9. Attach the free arm cover, bobbin holder and needle plate.

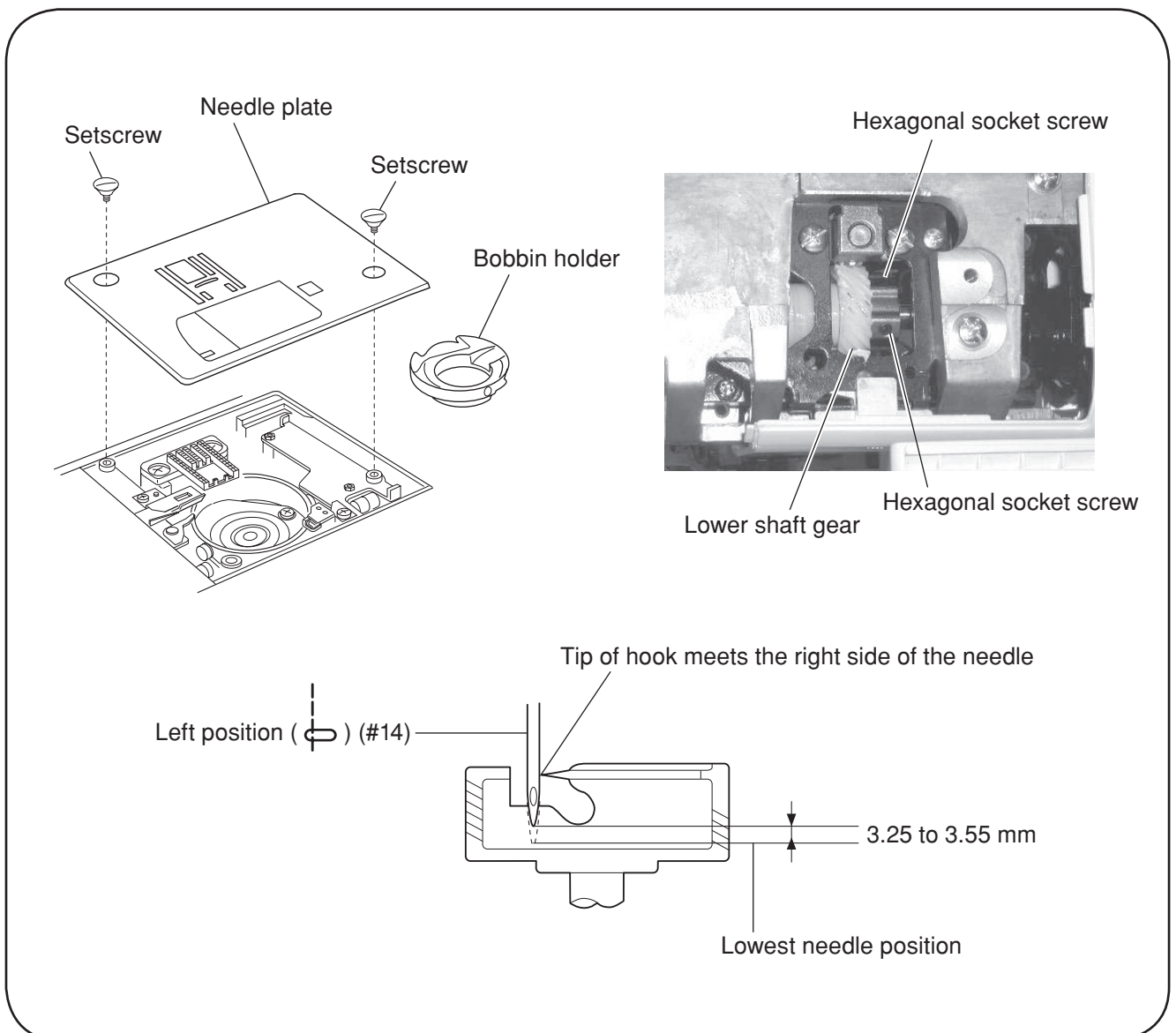

MECHANICAL ADJUSTMENT

ADJUSTMENT OF NEEDLE BAR HEIGHT

Before proceeding with this adjustment, check the hook timing (see page 11).

The distance between the upper edge of the needle eye and the tip of the hook should be in the range of 1.6 to 2.0 mm when the tip of the hook timing meets right side of the needle in the left needle position () as the needle ascends from its lowest position.

1. Remove the setscrews (2 pcs.) on the needle plate, the needle plate and the bobbin holder.
2. Turn the power switch on.
3. Select the pattern  (left position). Set the zigzag width at 0.
4. Turn the handwheel toward you until the tip of hook meets the right side of the needle.
5. Open the face cover.
6. Loosen the hexagonal socket screw.
7. Move the needle bar to adjust the needle bar height, and tighten the hexagonal socket screw.
Be careful not to turn the needle bar.
8. Attach the bobbin holder, needle plate and face cover.

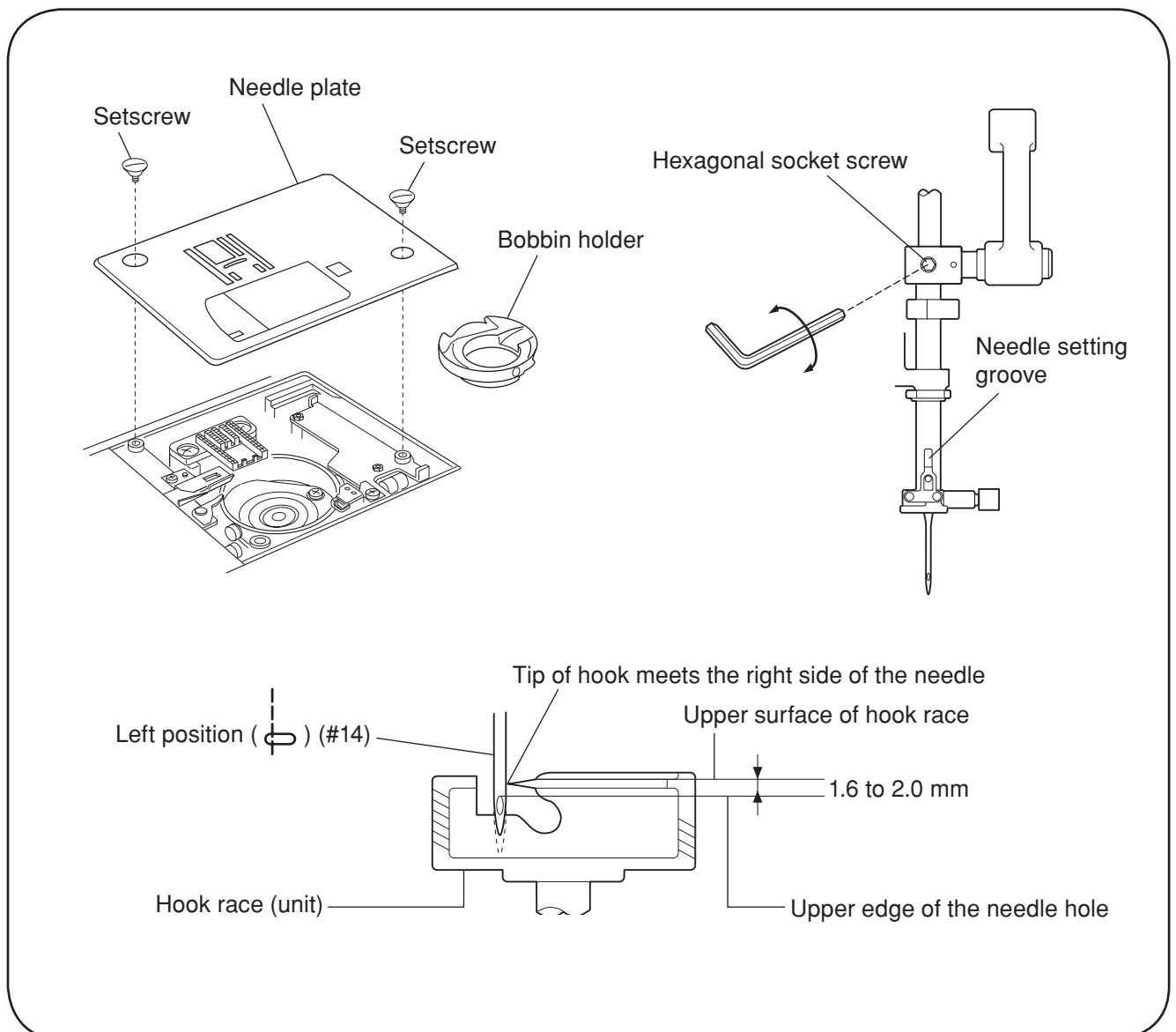

MECHANICAL ADJUSTMENT

CLEARANCE BETWEEN NEEDLE AND TIP OF THE ROTARY HOOK

* The clearance between the needle and the point of hook should be -0.10 to $+0.05$ mm.

Adjustment procedure:

1. Remove the setscrews A (2 pcs.) on the needle plate, the needle plate and the bobbin holder.
2. Attach the master needle. Turn the power switch on and set the zigzag width at maximum.
3. Open the face cover.
4. Loosen the setscrews B (2 pcs.).
5. Turn the handwheel toward you. Adjust the clearance between the needle and the tip of the rotary hook, by moving the needle bar supporter adjusting plate up or down, to within -0.10 to $+0.05$ mm at the left and right needle position.
6. Tighten the setscrews B (2 pcs.).
7. Attach the face cover. Remove the master needle. Attach the bobbin holder and needle plate.
8. Check the clearance between the needle and the edge of the needle plate hole (see page 10).

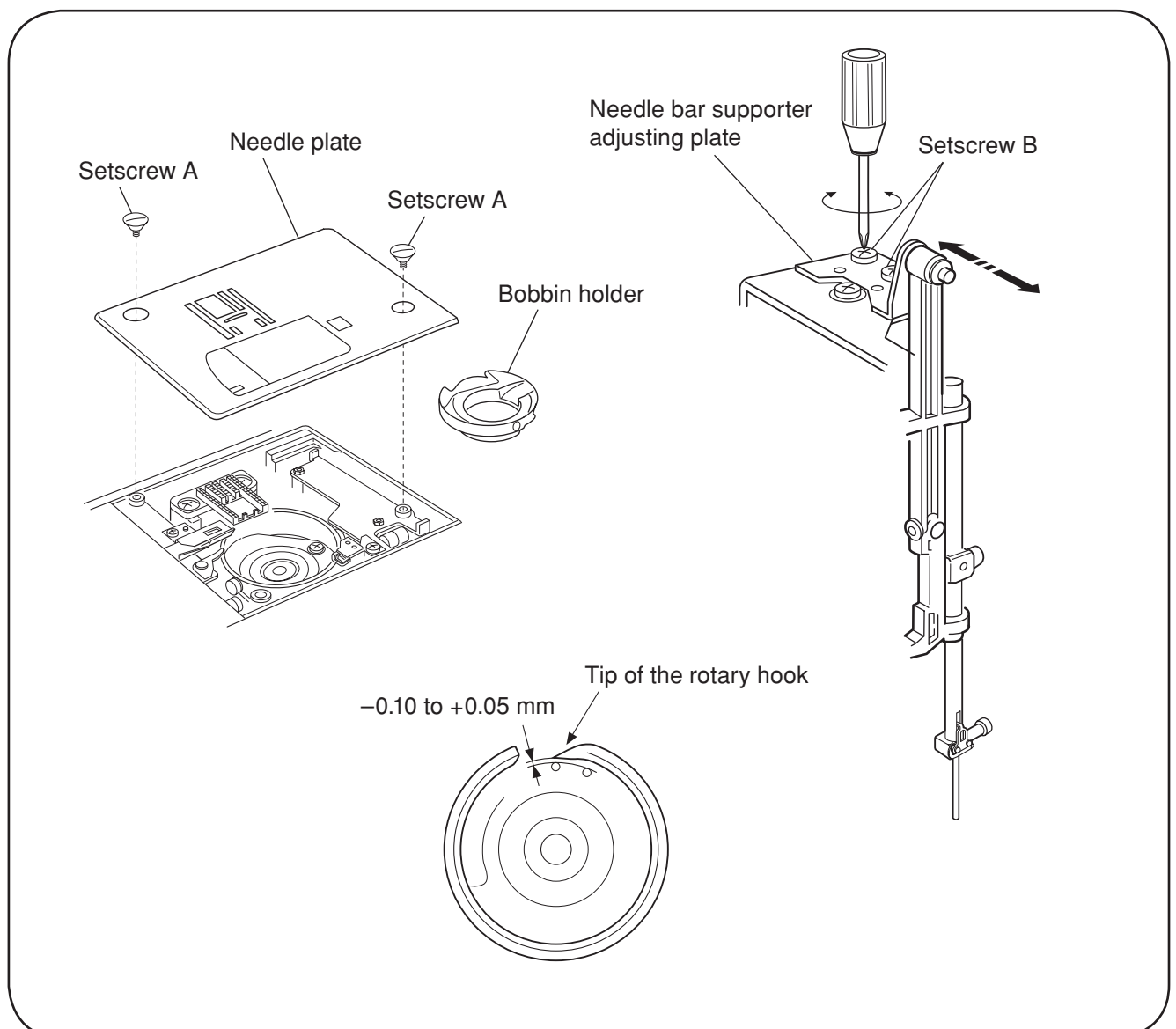

MECHANICAL ADJUSTMENT

FEED DOG HEIGHT

The highest position of the feed dog should be between 0.80 to 0.90 mm from the surface of the needle plate.

1. Lower the presser foot and turn the power switch on.
2. Turn the handwheel toward you to set the feed dog at the highest position.
3. Remove the free arm cover.
4. Loosen the setscrew ① and nut ②.
5. Adjust the feed dog height by turning the adjusting screw ③. The highest position of the feed dog should be between 0.80 to 0.90 from the surface of the needle plate.
6. Tighten the nut w and setscrew ①.
7. Attach the free arm cover.

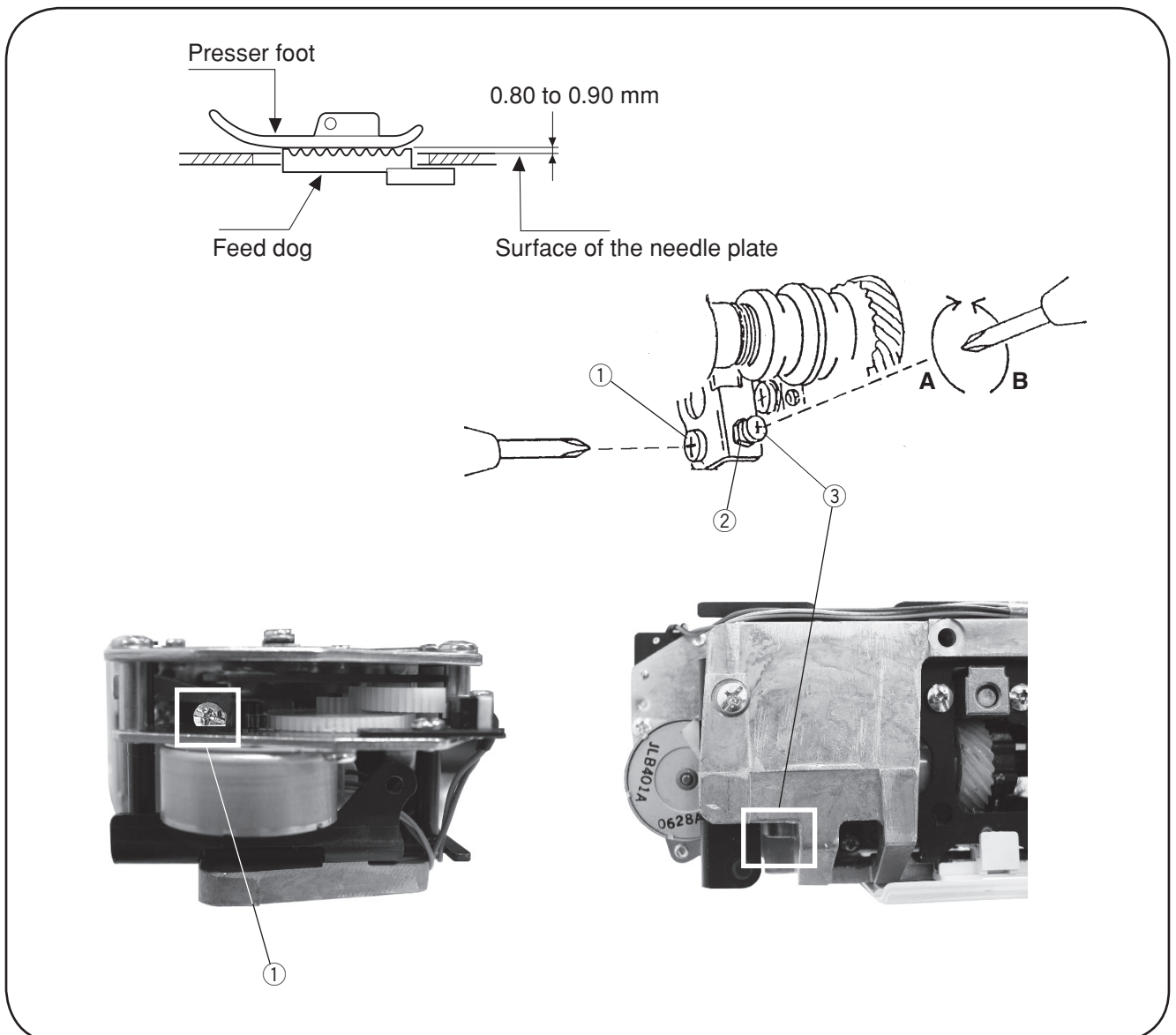

MECHANICAL ADJUSTMENT

FEED DOG ADJUSTMENT

The highest position of the feed dog should be parallel to the surface of the needle plate. If not, adjust as follows.

1. Use a hexagonal socket screw (4x6) ①.
Insert the hexagonal socket screw (4x6) to the hole ②.
Tighten the hexagonal socket screw (4x6) as far as it goes.
2. Loosen the setscrew ③ (left screw).
3. Turn hexagonal socket screw (4x6) to adjust the feed dog (should be parallel to the surface of the needle plate).
4. Tighten the setscrew e (left screw).
5. Loosen the hexagonal socket screw (4x6) and remove it.

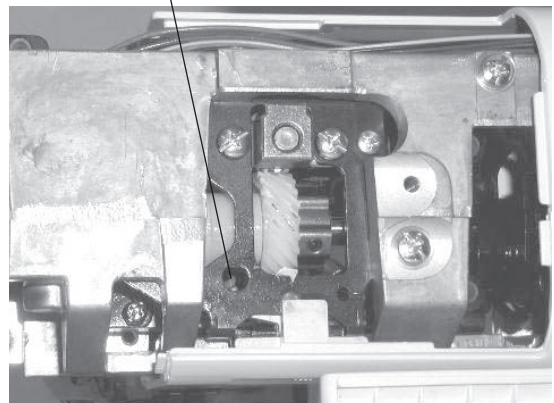
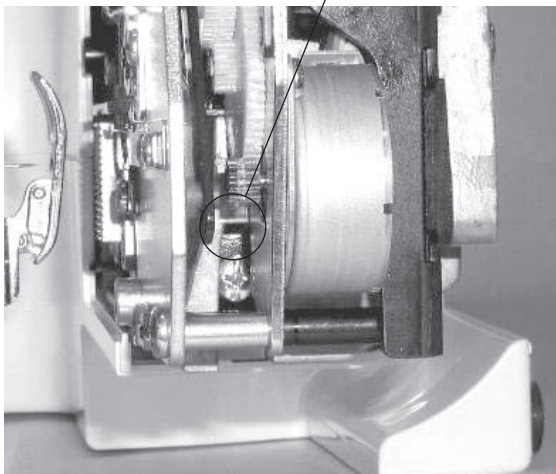
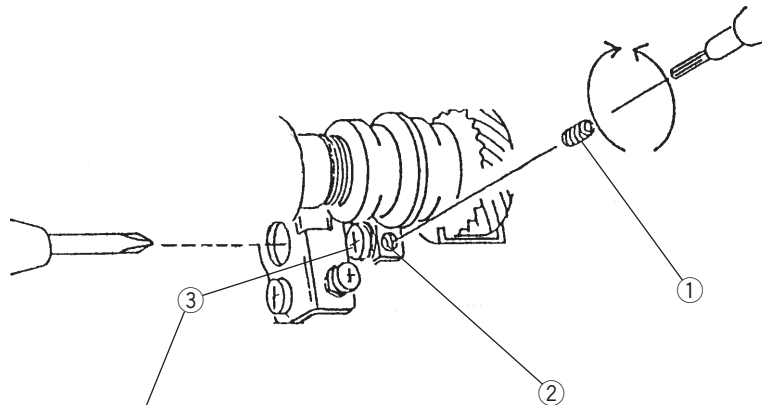

MECHANICAL ADJUSTMENT

TOP TENSION

The top tension should be between 65 to 80 grams-force when pulling the thread up in the direction of arrow.

* Use polyester sewing thread #50 (White).

* If it is not within the above limit, adjust as follows.

1. Set the tension dial "4".
2. Remove the front cover (see pages 6 to 7).
3. Lower the presser foot.
 - If the top tension is too loose, turn the lead screw in the direction (A).
 - If the top tension is too tight, turn the lead screw in the direction (B).
4. Check the top tension and attach the cover.

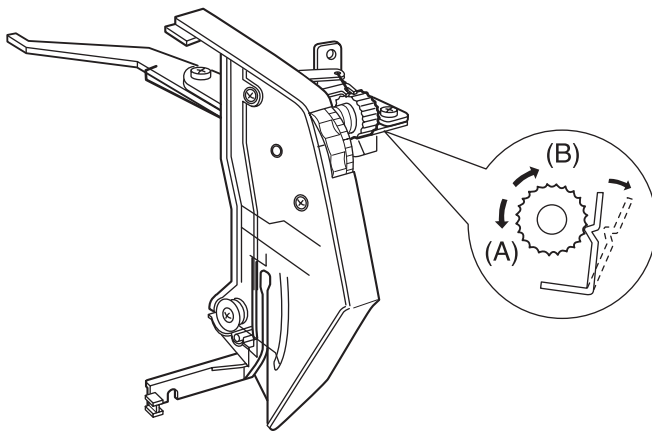

Pull the thread at the speed of 110 mm/sec in the direction of arrow

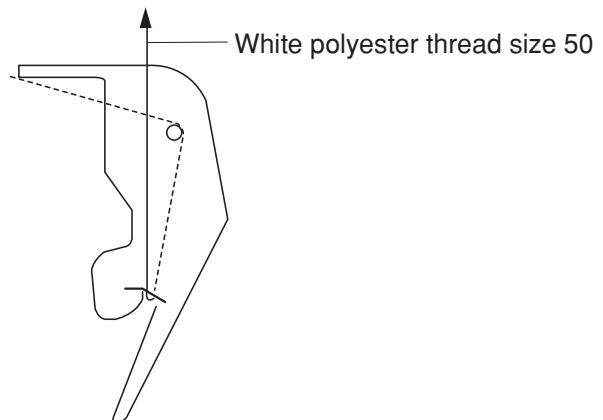

MECHANICAL ADJUSTMENT

STRETCH STITCH FEED BALANCE

To check:

1. Enter the self-diagnostic mode (see below).
Attach the Satin stitch foot F. Place a fabric under the presser foot. Lower the presser foot.
2. Press the locking stitch button to start test sew, and check the results (the standard figure length of 5 pieces of figure 8 is 33 to 39 mm).
3. If stretch patterns are distorted, correct them with the feed balancing dial.
If stretch patterns are too deformed and cannot be corrected with the feed balancing dial, adjust as follows.

To adjust:

4. Remove the feed balancing dial cover. Turn the dial at standard position as illustrated.
Turn the power switch ON.
Select the straight stitch and set the stitch length at "0". Place a fabric under the presser foot.
Lower the presser foot. (Do not set bobbin and needle threads)
5. Turn the hexagonal socket screw to the left to loosen it.
Move the gear up (A) or down (B) to adjust the feed.
* Do not move the gear right or left when adjusting.
Start the machine and check the movement of the fabric.
Adjust the hexagonal socket screw position (gear position) until the fabric will not be fed with the stitch length setting at "0".
6. Tighten the socket screw and attach the feed balancing dial cover.
Enter the self-diagnostic mode and test sew again. Check that the standard length of 5 pieces of figure 8 is 33 to 39 mm. If not, turn the feed balancing dial to correct it.

TO ENTER SELF-DIAGNOSTIC MODE:

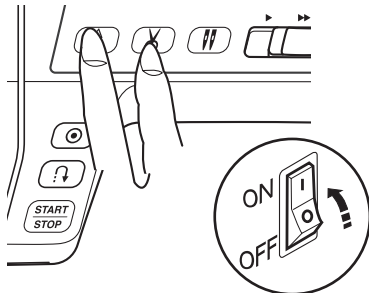

Turn the power switch on while simultaneously pressing needle up/down button and thread cutter button.

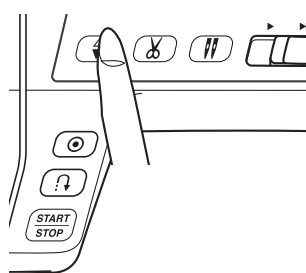

Press the needle up/down button within the 1.5 seconds to enter the self-diagnostic mode. The LCD will indicate "----". Press "8" to enter the stretch stitch test mode.

Incorrect Correct Incorrect

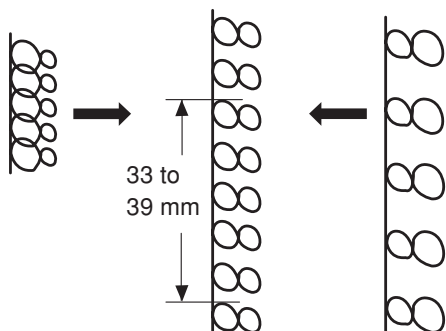

The standard figure length of 5 pieces of figure 8 is 33 to 39 mm.

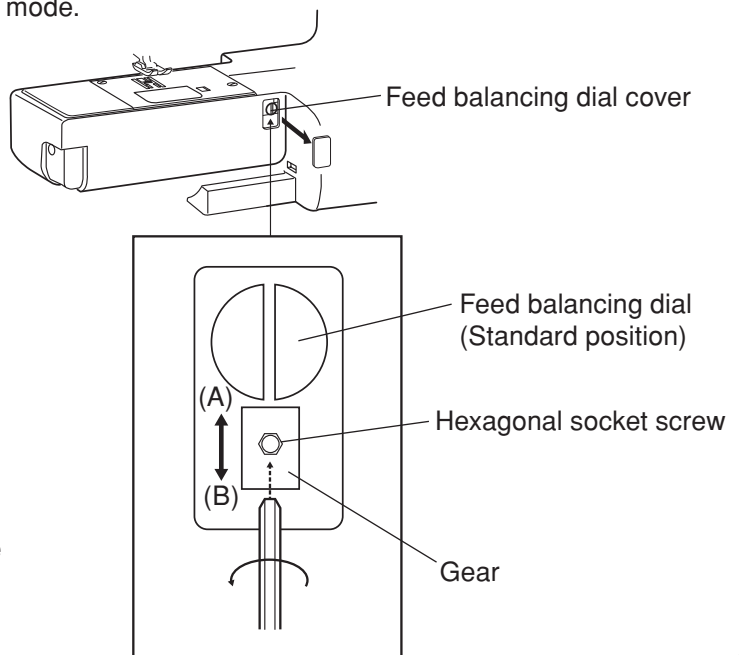

MECHANICAL ADJUSTMENT

ADJUSTING BUTTONHOLE LEVER POSITION

TO ADJUST THE BUTTONHOLE LEVER GUIDE:

1. Enter the self-diagnostic test of buttonhole sensor mode (see pages 25 and 26. The LCD should display 03 and BH symbol.)
2. Remove the face cover (see page 4) and loosen the setscrew ①.
3. Move the buttonhole lever guide ② so the BH symbol disappears when the buttonhole lever ③ is lowered. Tighten the setscrew.

TO ADJUST THE BUTTONHOLE SENSOR POSITION:

4. Attach the buttonhole foot (R) ④.
5. Lower the buttonhole lever ③ to its lowest position and open a 1.6 mm gap between the slider and the buttonhole foot.
6. Turn the adjusting screw ⑤ to the left until the LCD display BH symbol.
7. Next, turn the adjusting screw to the right until the BH symbol disappears.
8. Turn off the power switch.
9. Attach the face cover.

NOTE: If there is any lint or dust in the buttonhole sensor slit, loosen the setscrews (2 pcs.) ⑥ and clean it out with a swab.

TO ENTER BH REVER ADJUSTING MODE:

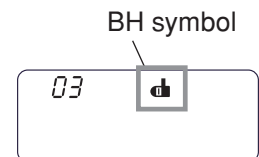
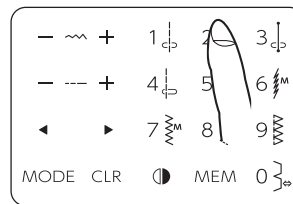
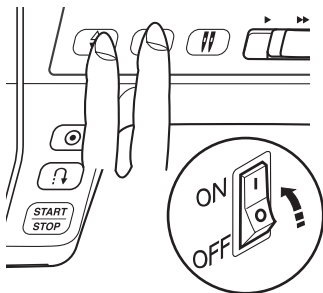

Turn the power switch on while simultaneously pressing needle up/down button and thread cutter button.

Press the needle up/down button within the 1.5 seconds to enter the self-diagnostic mode. The LCD will indicate "----".

Press the 1 key. Press the start/stop button two times to enter the BH lever adjusting mode.

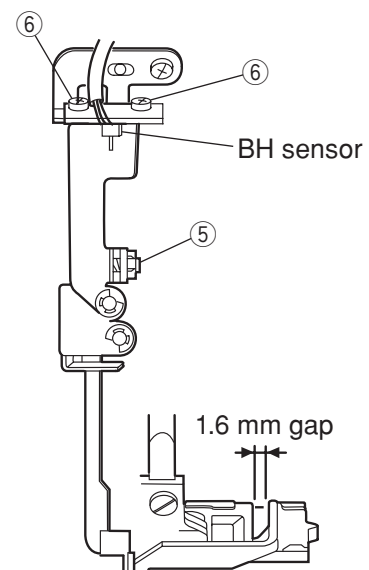
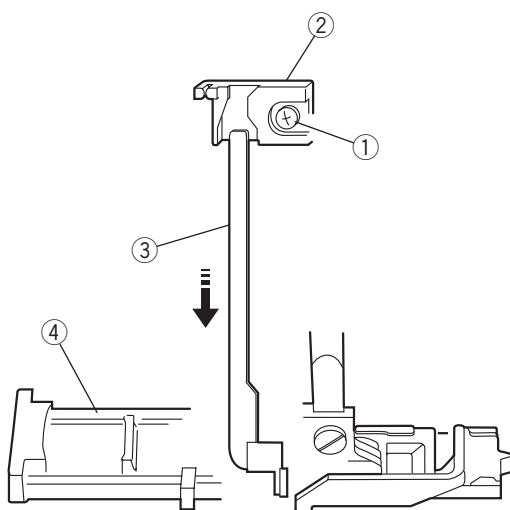

MECHANICAL ADJUSTMENT

REPLACING AND ADJUSTING THE PRESSER FOOT LIFTER SWITCH UNIT

To replace:

1. Remove the front cover and rear cover (see pages 5 to 7).
2. Remove the setscrew, replace the presser foot lifter switch.

To adjust:

3. Raise the presser foot lifter. Loosen the setscrew.
Move the presser foot lifter switch in the direction of the arrows to adjust the position of the switch.
The switch lever of the presser foot lifter switch should be pressed by the thread tension release lever.
Tighten the setscrew.
4. Enter the presser foot lifter switch adjusting mode.
5. Raise and lower the presser foot lifter to check if buzzer sounds.
6. Check if the the LCD display the presser foot symbol when the presser foot lifter is lowered (see FIG. 1) If not, go back to the procedure 1 and adjust the switch again.
7. Attach the rear cover and front cover.

TO ENTER PRESSER FOOT LIFTER SWITCH ADJUSTING MODE:

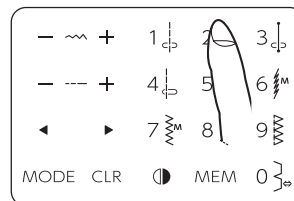
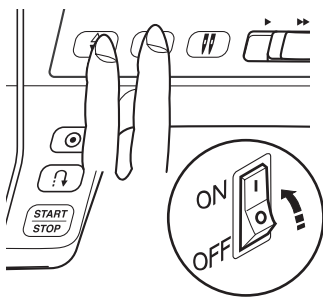

Presser foot symbol

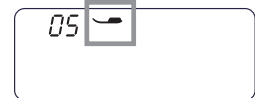

Turn the power switch on while simultaneously pressing needle up/down button and thread cutter button.

Press the needle up/down button within the 1.5 seconds to enter the self-diagnostic mode. The LCD will indicate "----".

Press the 1 key. Press the start/stop button four times to enter the presser foot lifter switch mode.

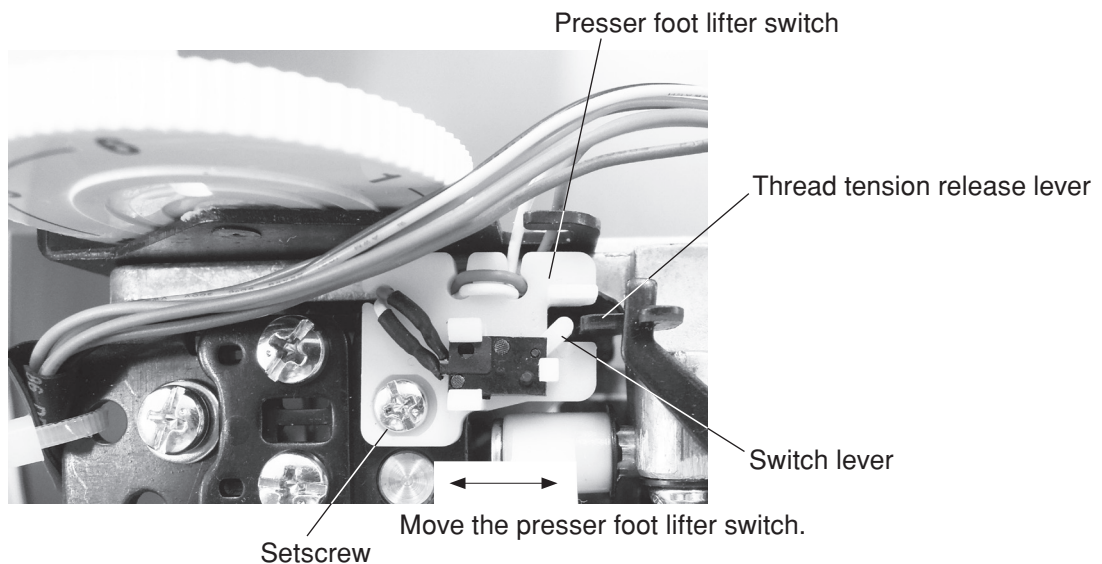

MECHANICAL ADJUSTMENT

REPLACING AND ADJUSTING THE KNEE LIFTER WIRE UNIT (1)

TO REPLACE KNEE LIFTER WIRE:

To remove:

1. Remove the free arm cover, base plate, front cover and rear cover (see pages 5 to 8).
2. Remove snap rings (2 pcs.).
3. Loosen nuts (3 pcs.).
4. Remove the wire (unit).

To attach:

5. Follow the above procedure in reverse.

After replacing the knee lifter wire (unit), follow the adjustment procedure on the next page.

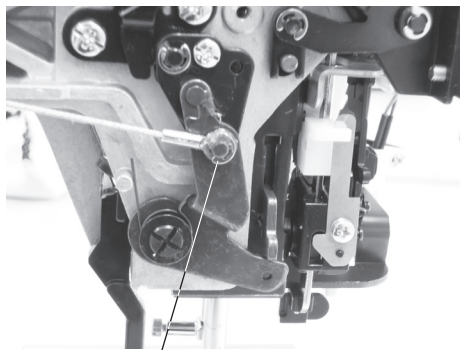

Snap ring

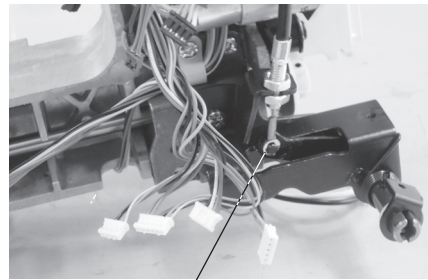

Snap ring

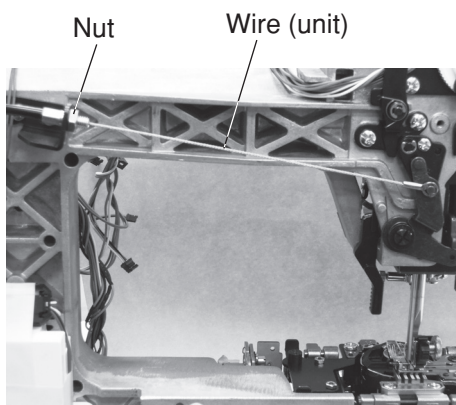

Nut

Wire (unit)

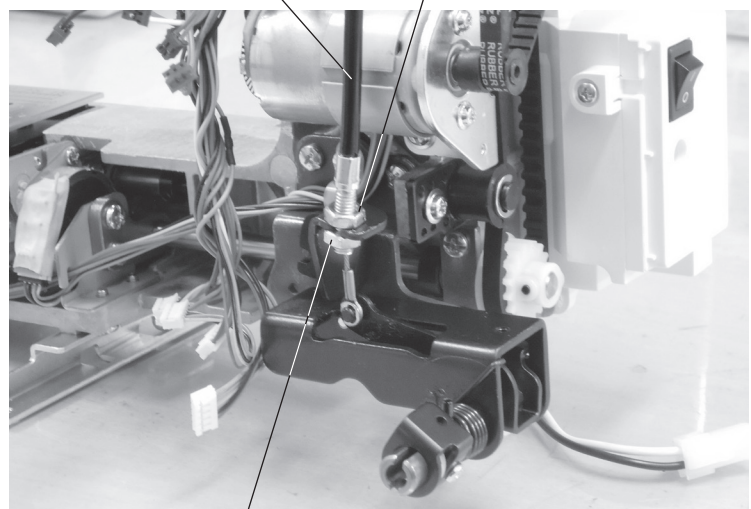

Wire (unit)

Nut

Nut

MECHANICAL ADJUSTMENT

REPLACING AND ADJUSTING THE KNEE LIFTER WIRE UNIT (2)

ADJUSTMENT OF KNEE LIFTER WIRE:

Adjustment method NO.1:

If the clearance between the knee lifter arm and presser bar supporter is too large (more than 0.3 mm), loosen nuts (2 pcs.) and make part A longer to adjust the clearance.

If the clearance between the knee lifter arm and presser bar supporter is too small (less than 0.1 mm), loosen nuts (2 pcs.) and make part A shorter to adjust the clearance.

Use the adjustment method NO.2 if the clearance cannot be adjusted to 0.1 to 0.3 mm by the method NO.1.

Adjustment method NO.2:

If the clearance between the knee lifter arm and presser bar supporter is too large (more than 0.3 mm), loosen setscrews (2 pcs.) and move the wire guide to the direction C to adjust the clearance.

If the clearance between the knee lifter arm and presser bar supporter is too small (less than 0.1 mm), loosen setscrews (2 pcs.) and move the wire guide to the direction D to adjust the clearance.

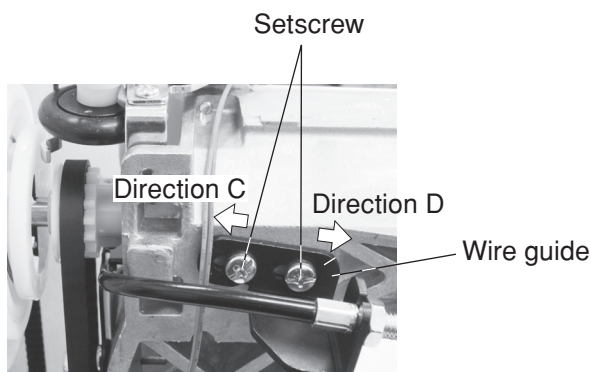
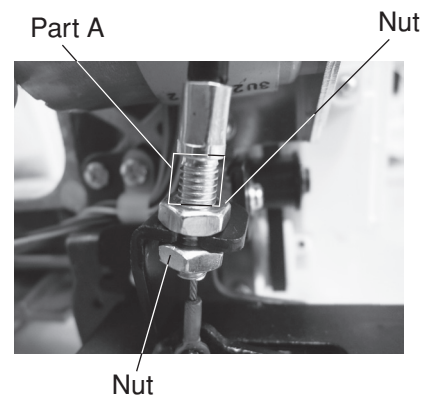
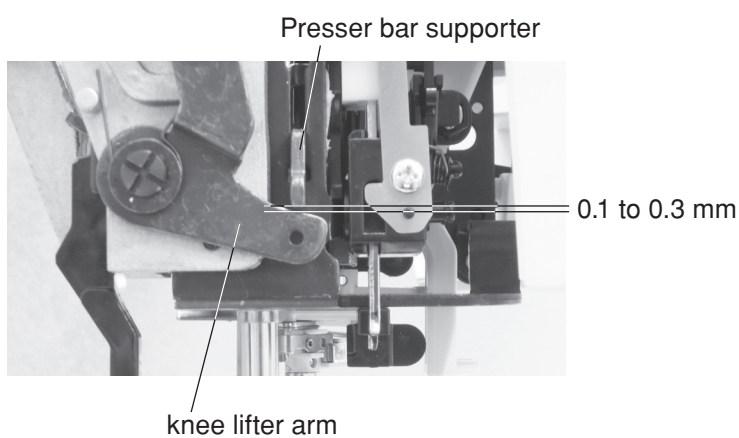

MECHANICAL ADJUSTMENT

REPLACING AND ADJUSTING THE NEEDLE THREADER HOLDER (1)

If the hook of the needle threader holder is damaged, change or adjust the part as follows:

To replace:

1. Remove the setscrew to remove the needle threader holder.
 2. Prepare the replacement parts (order them as necessary).
 - ① 858266009: Link plate 2
 - ② 862627108: Hook holder (unit)
 - ③ 862626026: Threader plate (unit)
 - ④ 858265008: Link plate 1
 - ⑤ 000230403: Setscrew ⑤
 3. Assemble the parts ①, ② and ④ as shown in FIG. 1.
 4. Attach the part ③ to the assembled parts as shown in FIG. 2.
 5. Attach the assembled parts with the setscrew ⑤.
- Be sure that the pin of the link plate is inserted in the slit as shown.
Adjust the needle threader hook position (see to the next page).

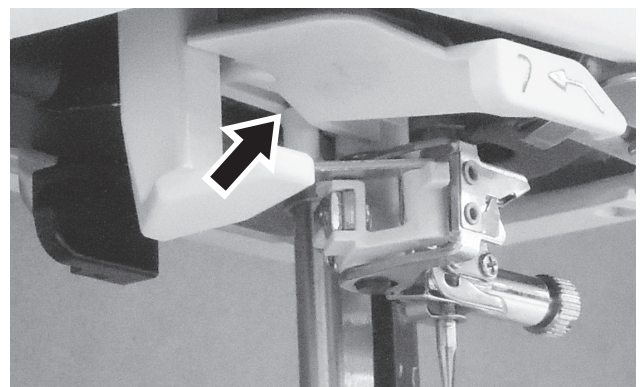
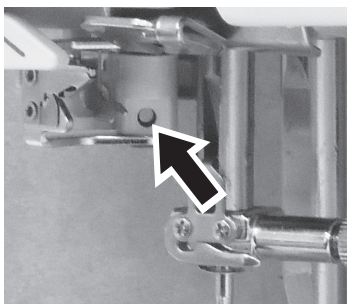
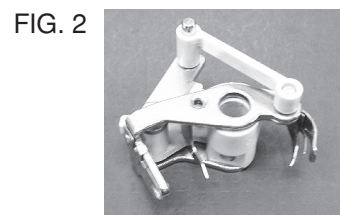
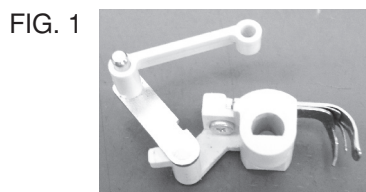
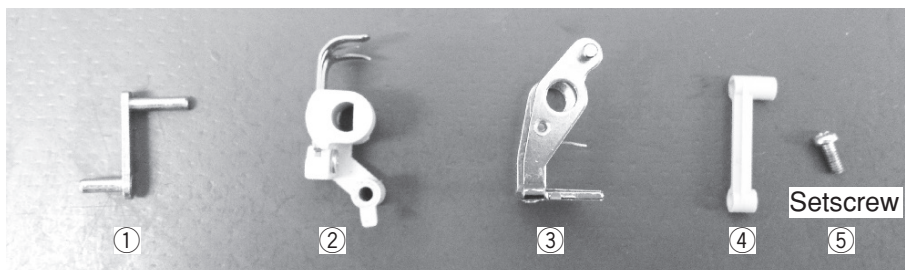
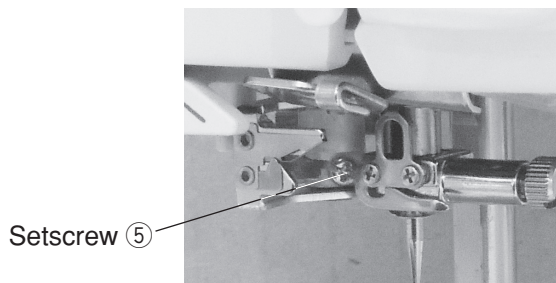

MECHANICAL ADJUSTMENT

REPLACING AND ADJUSTING THE NEEDLE THREADER HOLDER (2)

To adjust:

1. Push down the threader lever and hold it just before the threader hook enters the needle eye.
2. If the threader hook is not aligned vertically with the needle eye, loosen the hexagonal socket screw. Adjust the rotation pin stopper position so that the hook enters into the needle eye. Tighten the hexagonal socket screw.
3. If the threader hook is not aligned laterally with the needle eye, loosen the setscrew. Adjust the lateral position so that the hook enters into the needle eye. Tighten the setscrew.



Rotation pin stopper

Hexagonal socket screw



Setscrew

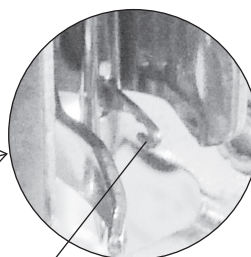

Hook

MECHANICAL ADJUSTMENT

THREAD CUTTER

The distance between the end of thread cutter plate slit and the edge of moving cutter should be in the range of 0.9 to 1.3 mm.

To check:

1. Remove the free arm cover (see page 5).
2. Turn the power switch off. Slide the moving cutter to the right with your finger.
3. Turn the power switch on.
The moving cutter motor is initialized, and moving cutter moves to its home position automatically.
4. The distance between the edge of moving cutter and the end of thread cutter plate slit should be 0.9 to 1.3 mm.
If not, follow the procedure below.

To adjust:

5. Loosen the setscrew on the sensor plate.
6. Adjust the distance between the end of thread cutter plate slit and the edge of moving cutter to 1.1 mm by moving the sensor plate in the direction of A or B.

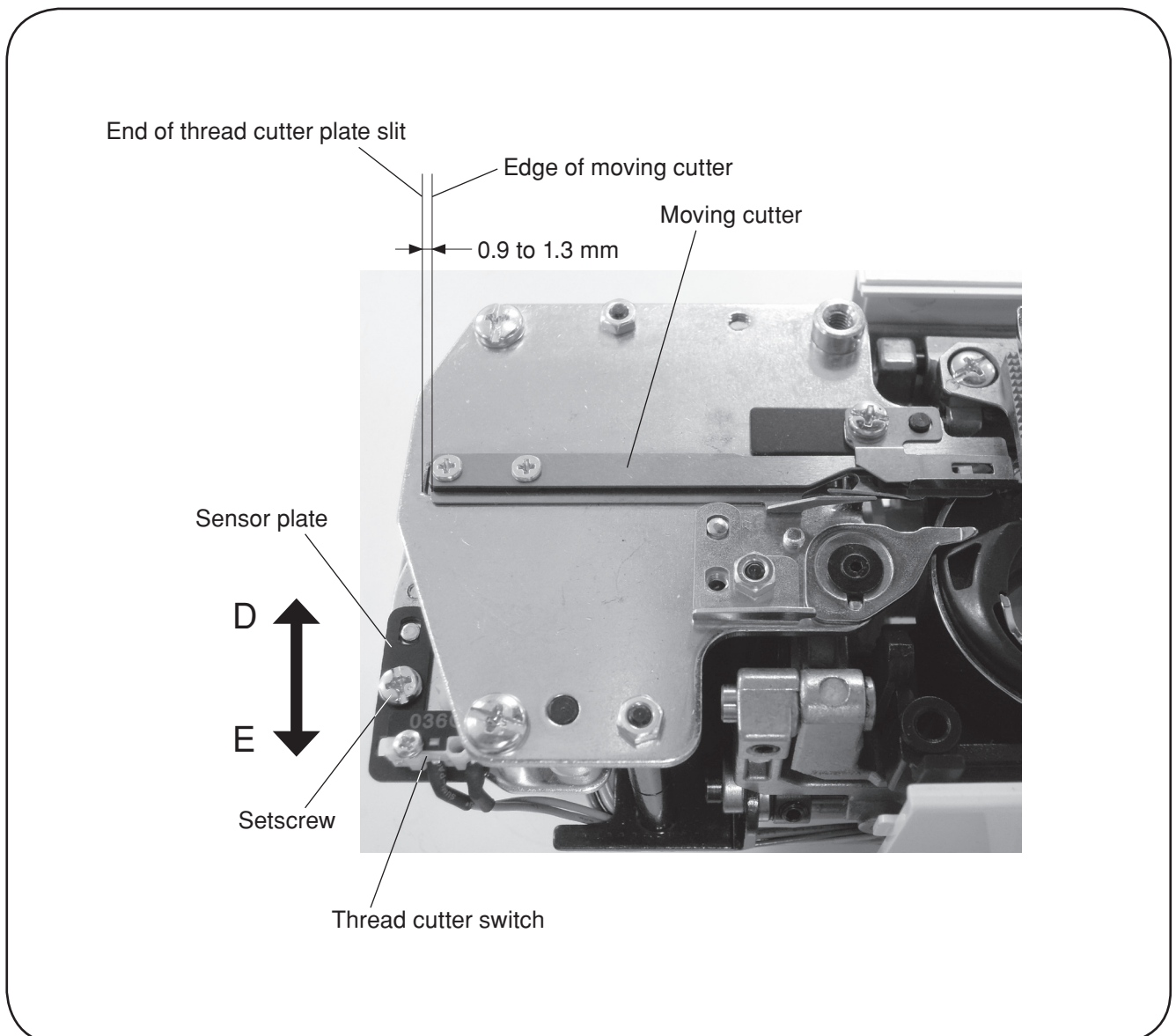

SELF-DIAGNOSTIC TEST

Preparation:

1. Turn the power switch off.
2. Move the bobbin winder spindle to the left.
3. Raise the feed dog.
4. Set the speed control lever to the left.
5. Remove the presser foot and raise the presser foot lifter.
6. Turn the hand wheel toward you to raise the needle to its highest position.

Notes:

- Be careful: the sewing machine may start running in its own while in test mode.
- Turn off the power switch before replacing any parts.
- Repeat the diagnostic test until the problem has been resolved.
- You can skip steps in the diagnostic procedure and go directly to the test you want to perform.
(Enter self-diagnostic mode, then select the step number of the diagnostic test you require by pressing the reverse stitch button)

To begin:

Turn on the switch. if any of the following problems occur, take the recommended actions in the order they are shown.

1. The machine does not respond when the power switch is turned on:
 - Check each connector connection
 - Replace the switching regulator
 - Replace the printed circuit board A
2. The sewing machine lamp does not light up:
 - Replace the printed circuit board L
 - Replace the printed circuit board A

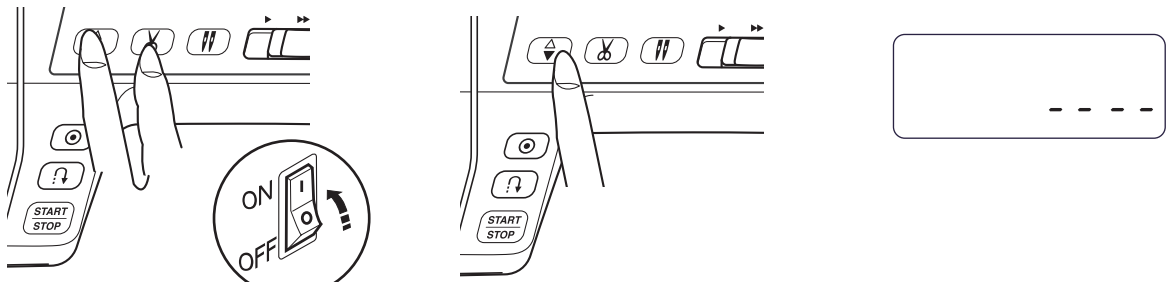

TO ENTER SELF-DIAGNOSTIC MODE:





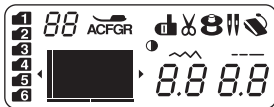
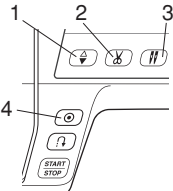

Turn the power switch on while simultaneously pressing needle up/down button and thread cutter button.

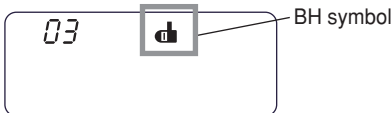
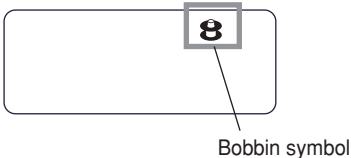
Press the needle up/down button within the 1.5 seconds to enter the self-diagnostic mode.
The LCD will indicate "----".



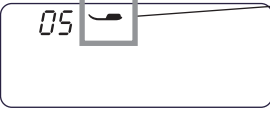
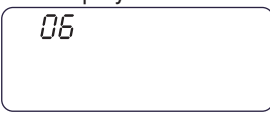

SELF-DIAGNOSTIC TEST

STEP AND ITEMS TO CHECK	PROCEDURE	CORRECT CONDITION	DEFECTIVE CONDITION
<p>01) FUNCTION OF LCD, BUZZER AND LAMP</p>	<p>Turn on the power switch while simultaneously pressing the needle up/down button and thread cutter button.</p> <p>Press the needle up/down button within the 1.5 seconds to enter the self-diagnostic mode.</p> <p>Press the "1" key.</p> <p>If the result is correct condition, press the start/stop button to proceed the next step.</p> <p>If the result is defective condition, press the reverse stitch button to proceed the next step.</p>	<p>Sewing lamp and LCD backlight lit. LCD displays "----".</p>  <p>Buzzer sounds. LCD displays symbols and numbers and blinks.</p> 	<p>Sewing lamp does not lit. LCD backlight does not lit. LCD does not display. Buzzer does not sound. LCD does not turned on. LCD does not display any symbols or not in order.</p> <p>-REMEDY- Replace the printed circuit board A. Replace the machine lamp. Replace the touch panel. Replace the printed circuit board F.</p>
<p>02) BUTTON</p>	 <p>Press the buttons 1 to 4.</p> <p>If the result is correct condition, press the start/stop button to proceed the next step.</p> <p>If the result is defective condition, press the reverse stitch button to proceed the next step.</p>	<p>LCD displays "02".</p> <p>Buzzer sounds when button is pressed. Button number is displayed when the button is pressed.</p>  <p>LCD DISPLAYS "S1" WHEN BUTTON 1 IS PRESSED. LCD DISPLAYS "S2" WHEN BUTTON 2 IS PRESSED. LCD DISPLAYS "S3" WHEN BUTTON 3 IS PRESSED. LCD DISPLAYS "F3" WHEN BUTTON 4 IS PRESSED.</p>	<p>Buzzer does not sound. LCD does not display the number correctly.</p> <p>-REMEDY- Replace the printed circuit board A. Replace the printed circuit board F2.</p>
<p>03) BUTTONHOLE SENSOR</p>	<p>Lower the buttonhole lever.</p> <p>Move the buttonhole lever back and forth.</p> <p>If the result is correct condition, press the start/stop button to proceed the next step.</p> <p>If the result is defective condition, press the reverse stitch button to proceed the next step.</p>	<p>LCD displays "03".</p> <p>When the buttonhole lever is pulled, buzzer sounds and LCD displays BH symbol.</p>  <p>When the buttonhole lever is pushed, buzzer sounds and LCD displays BH symbol.</p>	<p>Buzzer does not sound. BH symbol does not appear.</p> <p>-REMEDY- Adjust the BH lever sensor position. Replace the BH lever sensor. Replace the printed circuit board A.</p>
<p>04) BOBBIN WINDER SWITCH</p>	<p>Move the bobbin winder spindle to the right.</p> <p>Return it to the left.</p> <p>If the result is correct condition, press the start/stop button to proceed the next step.</p> <p>If the result is defective condition, press the reverse stitch button to proceed the next step.</p>	<p>LCD displays "04".</p> <p>When the bobbin winder spindle is moved to the right, buzzer sounds and LCD displays the bobbin symbol.</p> <p>When the bobbin winder spindle is moved to the left, buzzer sounds and LCD displays "04".</p> 	<p>Buzzer does not sound. Bobbin symbol is not displayed.</p> <p>-REMEDY- Adjust the bobbin winder switch position. Replace the bobbin winder switch. Replace the printed circuit board A.</p>

SELF-DIAGNOSTIC TEST

STEP AND ITEMS TO CHECK	PROCEDURE	CORRECT CONDITION	DEFECTIVE CONDITION
05) PRESSER FOOT LIFTER SWITCH	<p>Move the presser foot lifter up and down.</p> <p>If the result is correct condition, press the start/stop button to proceed the next step.</p> <p>If the result is defective condition, press the reverse stitch button to proceed the next step.</p>	<p>LCD displays "05".</p> <p>When the presser foot lifter is lowered, buzzer sounds and LCD displays presser foot symbol.</p>  <p>Presser foot symbol</p> <p>When the buttonhole lever is raised, buzzer sounds and the presser foot symbol disappears.</p>	<p>Buzzer does not sound. Presser foot symbol does not appear.</p> <p>–REMEDY– Adjust the presser foot lifter switch position. Replace the presser foot lifter switch. Replace the printed circuit board A.</p>
06) UPPER SHAFT POSITIONING SENSOR	<p>Turn the handwheel toward you. Lower the needle bar from its highest to lowest position. Raise the needle bar from its lowest position to highest position.</p> <p>If the result is correct condition, press the start/stop button to proceed the next step.</p> <p>If the result is defective condition, press the reverse stitch button to proceed the next step.</p>	<p>LCD displays "06".</p>  <p>Turn the handwheel. LCD displays stitch width symbol when the needle bar is at zigzag phase.</p>  <p>Stitch width symbol</p> <p>LCD displays stitch length symbol when the needle bar is at feed phase.</p>  <p>Stitch length symbol</p>	<p>Buzzer does not sound. Stitch width or length symbol does not appear.</p> <p>–REMEDY– Replace the printed circuit board A. Replace the printed circuit board P.</p>
07) ZIGZAG MOTOR (STEP MOTOR) AND FEED MOTOR	<p>Turn the handwheel toward you. Raise the needle bar to its highest to position (zigzag phase). Press the needle up/down button.</p> <p>Lower the needle bar from its highest position to its lowest position (feed phase). Press the needle up/down button.</p> <p>If the result is correct condition, press the start/stop button to proceed the next step.</p> <p>If the result is defective condition, press the reverse stitch button to proceed the next step.</p>	<p>LCD displays "07".</p>  <p>Stitch width symbol</p> <p>Press the needle up/down button when LCD displays stitch width symbol. The Zigzag motor will be initialized and get its default position.</p>  <p>Stitch length symbol</p> <p>Press the needle up/down button when LCD displays stitch length symbol. The feed motor will be initialized and get its default position.</p>	<p>Zigzag motor does not get default position. Buzzer does not sound.</p> <p>–REMEDY– Replace the zigzag motor. Replace the printed circuit board A.</p> <p>Feed motor does not get default position. Buzzer does not sound.</p> <p>–REMEDY– Replace the feed motor. Replace the printed circuit board A.</p>

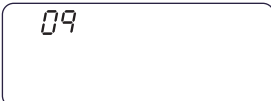
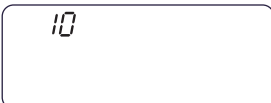
SELF-DIAGNOSTIC TEST

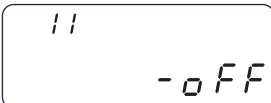
STEP AND ITEMS TO CHECK	PROCEDURE	CORRECT CONDITION	DEFECTIVE CONDITION
08) FOOT CONTROL	Attach the foot control to the machine. Depress the foot control as far as it goes, then release it. If the result is correct condition, press the start/stop button to proceed the next step. If the result is defective condition, press the reverse stitch button to proceed the next step.	LCD displays "08".  The foot control symbol appears when the foot control is attached.  Buzzer sounds when the foot control is deeply depressed. Buzzer sounds when the foot control is released.	The foot control symbol does not appear. Buzzer does not sound. –REMEDY– Replace the foot control. Replace the machine socket (foot control socket). Replace the printed circuit board A.
09) SLIDE VOLUME	Shift the slide volume from left to right, then return to the left. If the result is correct condition, press the start/stop button to proceed the next step. If the result is defective condition, press the reverse stitch button to proceed the next step.	LCD displays "09".  Buzzer sounds at rightmost or leftmost position.	Buzzer does not sound. –REMEDY– Replace the printed circuit board A.
10) DC MOTOR	Press the needle up/down button. If the result is correct condition, press the start/stop button to proceed the next step. If the result is defective condition, press the reverse stitch button to proceed the next step.	LCD displays "10".  Machine runs slow, then fast, and the needle bar stops at its highest position. LCD displays "OK".	The machine motor does not start. The motor stops immediately. The motor runs unstable. LCD displays "NG". –REMEDY– Replace the DC motor. Replace the printed circuit board A.
11) THREAD TENSION RELEASE SOLENOID	Lower the presser foot. Press the needle up/down button. If the result is correct condition, press the start/stop button to proceed the next step. If the result is defective condition, press the reverse stitch button to proceed the next step.	LCD displays "11" and "–off". Press the needle up/down button to switch the solenoid on or off. [ON] Buzzer sounds and the thread tension disk opens, and LCD displays "–on" while the thread tension disk opens. The thread tension disk will be closed automatically 5 seconds after the thread tension released.  [OFF] Buzzer sounds and the thread tension disc closes, and LCD displays "–off". 	The thread tension disk does not open. –REMEDY– Replace the solenoid. Replace the printed circuit board A.

SELF-DIAGNOSTIC TEST

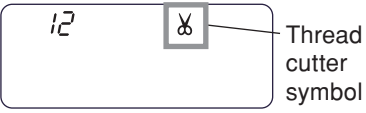
STEP AND ITEMS TO CHECK	PROCEDURE	CORRECT CONDITION	DEFECTIVE CONDITION
<p>12) THREAD CUTTER MOTOR, THREAD CUTTER SOLENOID</p>	<p>Turn the handwheel toward you to raise the needle bar at its highest position. Press the needle up/down button.</p> <p>If the result is correct condition, press the start/stop button to proceed the next step.</p> <p>If the result is defective condition, press the reverse stitch button to proceed the next step.</p>	<p>LCD displays "12".</p> <p>The thread cutter symbol will blink, and thread cutter motor will be initialized.</p> <div style="text-align: center;">  <p>The diagram shows a rectangular LCD display area. On the left side, the number '12' is displayed. On the right side, there is a small square box containing a scissors icon. A horizontal line extends from the right side of this box to the text 'Thread cutter symbol'.</p> </div>	<p>Thread cutter motor does not work.</p> <p>The thread cutter symbol does not appear when thread cutter is at its initialized position.</p> <p>Thread cutter position is not initialized and caution Buzzer sounds.</p> <p>–REMEDY–</p> <p>Replace the thread cutter motor.</p> <p>Replace the thread cutter initialize switch.</p> <p>Replace the printed circuit board A.</p>

SELF-DIAGNOSTIC TEST

Buzzer sounds after few seconds when the self-diagnostic test has been finished.
The test result has been determined.

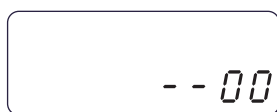

CORRECT:

Buzzer sounds and LCD displays "00"



DEFECTIVE:

Caution buzzer sounds and LCD displays the defective part number.
See pages 26 to 29 and fix the defective part.

The defective part number.
See pages 26 to 29 "Steps
and items" section.

Turn the power switch off when the self-diagnostic test is finished.

TO DISPLAY THE VERSION OF THE PROGRAM

Turn the power switch on while simultaneously pressing needle up/down button and thread cutter button.

Press the needle up/down button within the 1.5 seconds to enter the self-diagnostic mode.
The LCD will indicate "----".

Press the touch panel "3" to display the version of the program.

REPLACING THE ELECTRONIC COMPONENTS

PRINTED CIRCUIT BOARD A CONNECTION

NOTE:

Do not disconnect the connectors by pulling on cord.
To disconnect, grasp the connector, not the cord.

- | | |
|-----------------------------------|---|
| ① Printed circuit board F (white) | ⑩ Power switch (white) |
| ② Printed circuit board L (white) | ⑪ DC Motor (white) |
| ③ Program (black) | ⑫ Stitch width motor (green) |
| ④ Bobbin winding switch (blue) | ⑬ Solenoid (thread tension release control) (black) |
| ⑤ Thread cutter motor (white) | ⑭ Micro switch (presser foot lifter sensor) (green) |
| ⑥ Touch panel (white) | ⑮ Printed circuit board E1 (BH sensor) (red) |
| ⑦ Feed motor (white) | ⑯ Auto-off timer switch (black) |
| ⑧ Printed circuit board P (black) | |
| ⑨ Controller (black) | |

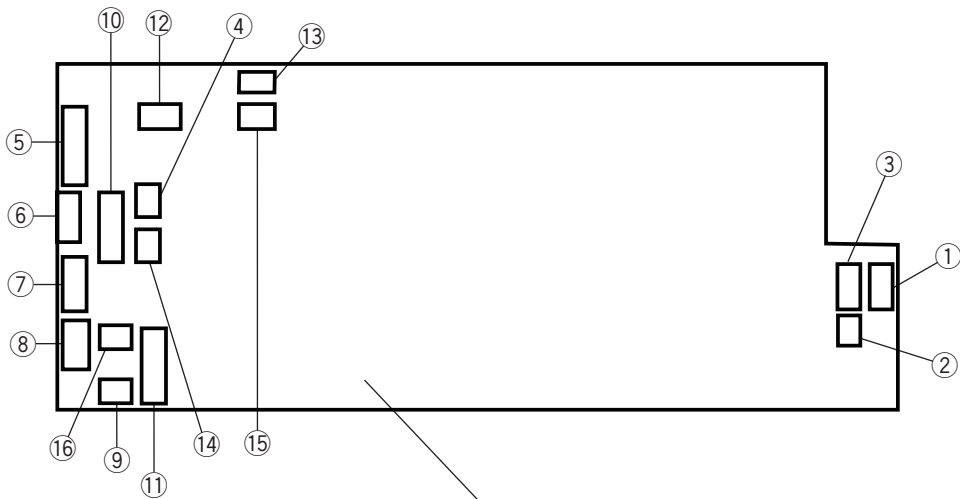

Printed circuit board A

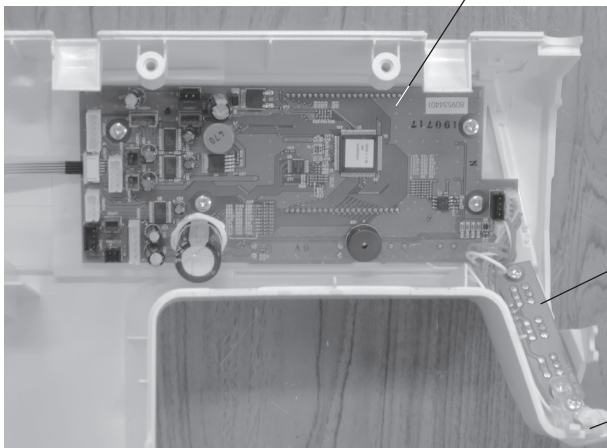

Printed circuit board F

Printed circuit board L

REPLACING THE ELECTRONIC COMPONENTS

PRINTED CIRCUIT BOARD A

To remove:

1. Remove the front cover (see pages 6 to 7)
2. Pull out connectors from the printed circuit board A.
3. Remove the setscrews (4 pcs.) and the printed circuit board A.

To attach:

4. Follow the above procedures in reverse.

NOTE:

Do not disconnect the connectors by pulling on cord.
To disconnect, grasp the connector, not the cord.

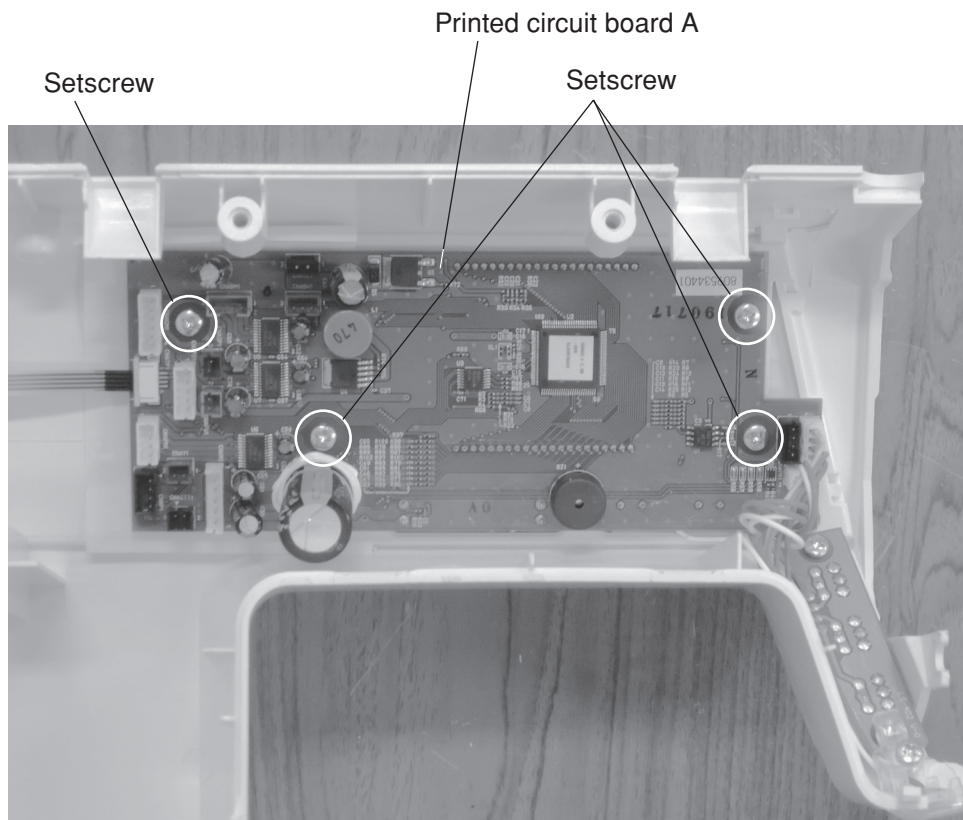

REPLACING THE ELECTRONIC COMPONENTS

DRIVING MOTOR

To remove:

1. Remove the front cover (see pages 6 and 7).
2. Remove the setscrews (2 pcs.) and the driving motor and the belt.

To attach:

3. Install the driving motor and the motor belt. Tighten them with setscrews (2 pcs.) lightly.
4. Move the motor up or down to adjust the motor belt tension.
The belt should deflect 7 to 9 mm when applying 300 grams-force of load to the middle of the belt.
Tighten the setscrews (2 pcs.) firmly.
5. Attach the rear cover and the front cover.

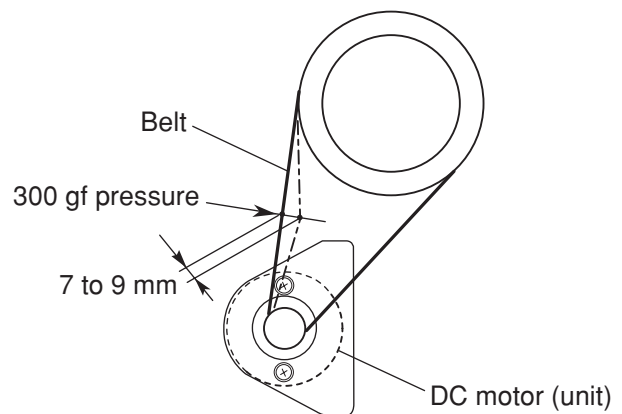
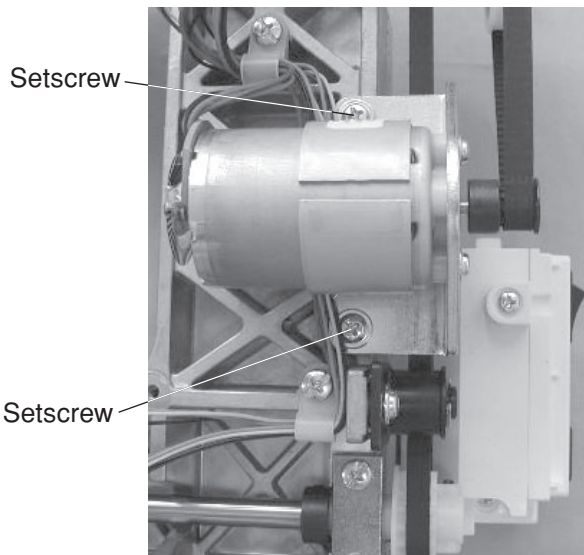

REPLACING THE ELECTRONIC COMPONENTS

SWITCHING REGULATOR UNIT

To remove:

1. Remove the front cover and the rear cover (see pages 6 to 8).
2. Remove the setscrews (3 pcs.) and the switching regulator with cords.

To attach:

3. Follow the above procedures in reverse.
Be sure to connect the connectors (switching regulator connector (5P), controller connector (2P) and auto-off timer switch connector (2P)) to the circuit board A (see page 31).

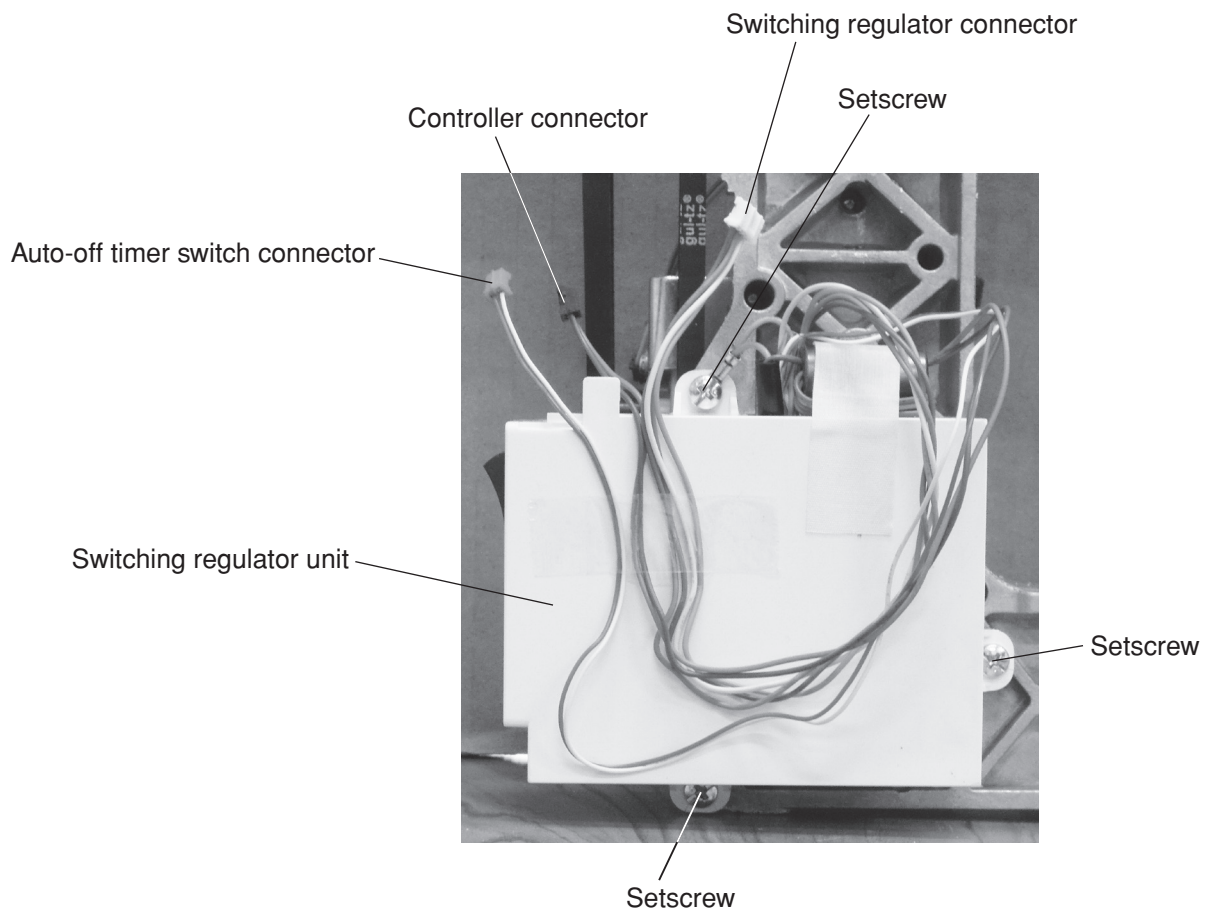

CLEANING AREA OF THREAD CUTTER AND LOWER SHAFT GEAR

Remove the dust on the area of the thread cutter and the lower shaft gear as follow.

1. Remove the free arm cover (see page 5).
2. Clean the area of the thread cutter and the lower shaft gear.
3. After cleaning, attach the free arm cover.

Thread cutter

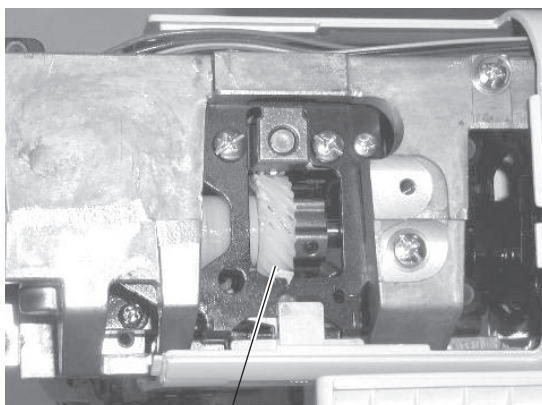
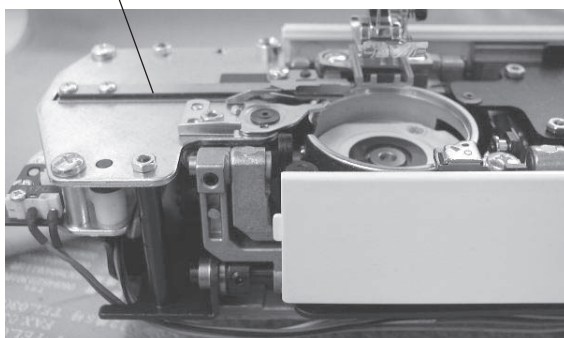

Lower shaft gear

KEY POSITION ADJUSTMENT

You can adjust the key position when the key sensor is off from the actual key position.

Printed the touch panel key position adjustment guide on page 37 to its actual size.

Cut off the touch panel guide.

Attach the guide on the touch panel with an adhesive tape.

Adjust the key position as follows:

To adjust:

1. Enter the key position adjusting mode (see FIG. 1).
2. The key position adjustment screen appears and "P1" is shown on the right side of the LCD display.
3. With a buttonhole opener, press ① on the touch panel of your machine (see FIG. 2). "P2" will be shown on the LCD display.
Press the ② on the touch panel. "P3" will be shown on the LCD display.
Press the ③ on the touch panel. "P4" will be shown on the LCD display.
Press the ④ on the touch panel. "P5" will be shown on the LCD display.
Press the ⑤ on the touch panel. "----" will be shown on the LCD display.
Buzzer sounds after the ⑤ on the touch panel has been pushed.
4. Turn off the power switch.

FIG. 1

TO ENTER KEY POSITION ADJUSTING MODE:

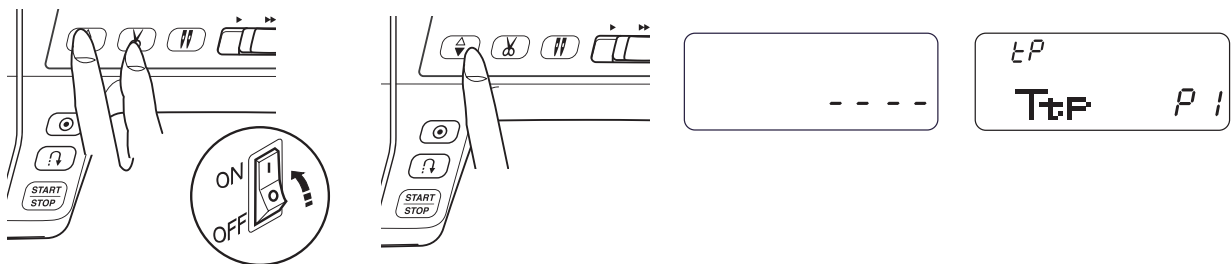

Turn the power switch on while simultaneously pressing needle up/down button and thread cutter button.

Press the needle up/down button within the 1.5 seconds to enter the self-diagnostic mode. The LCD will indicate "----".

Press the "4" key to enter the key position adjusting mode.

FIG. 2

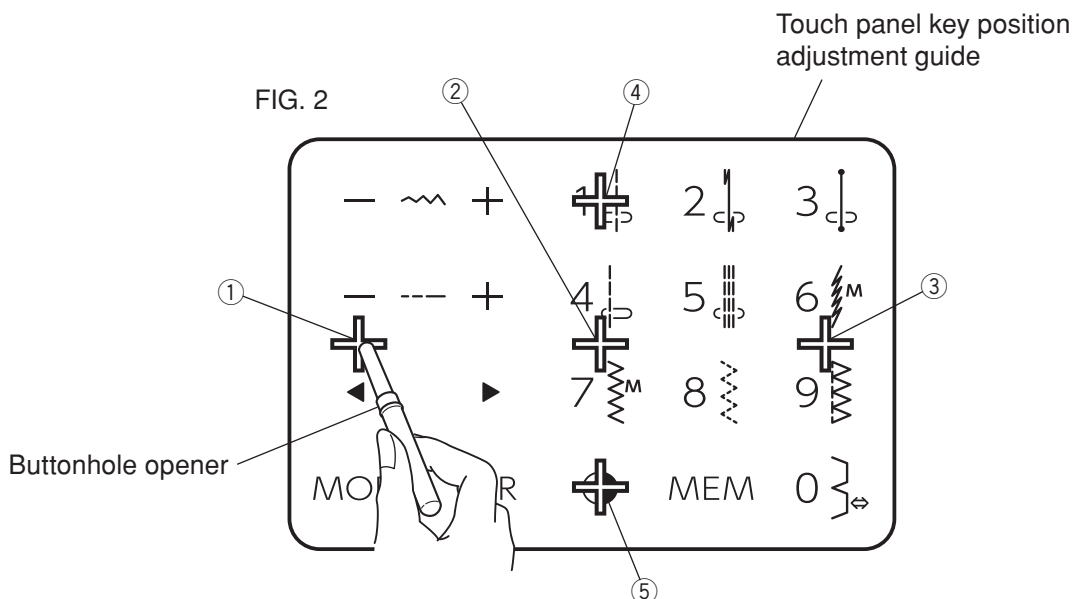

TOUCH PANEL KEY POSITION ADJUSTMENT GUIDE

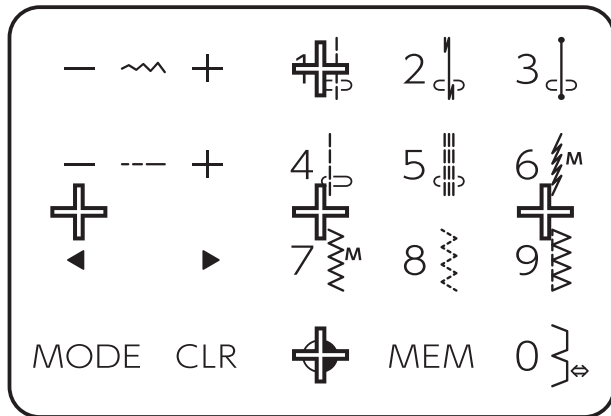

Print this illustration (guide) to its actual size.

PARTS LIST

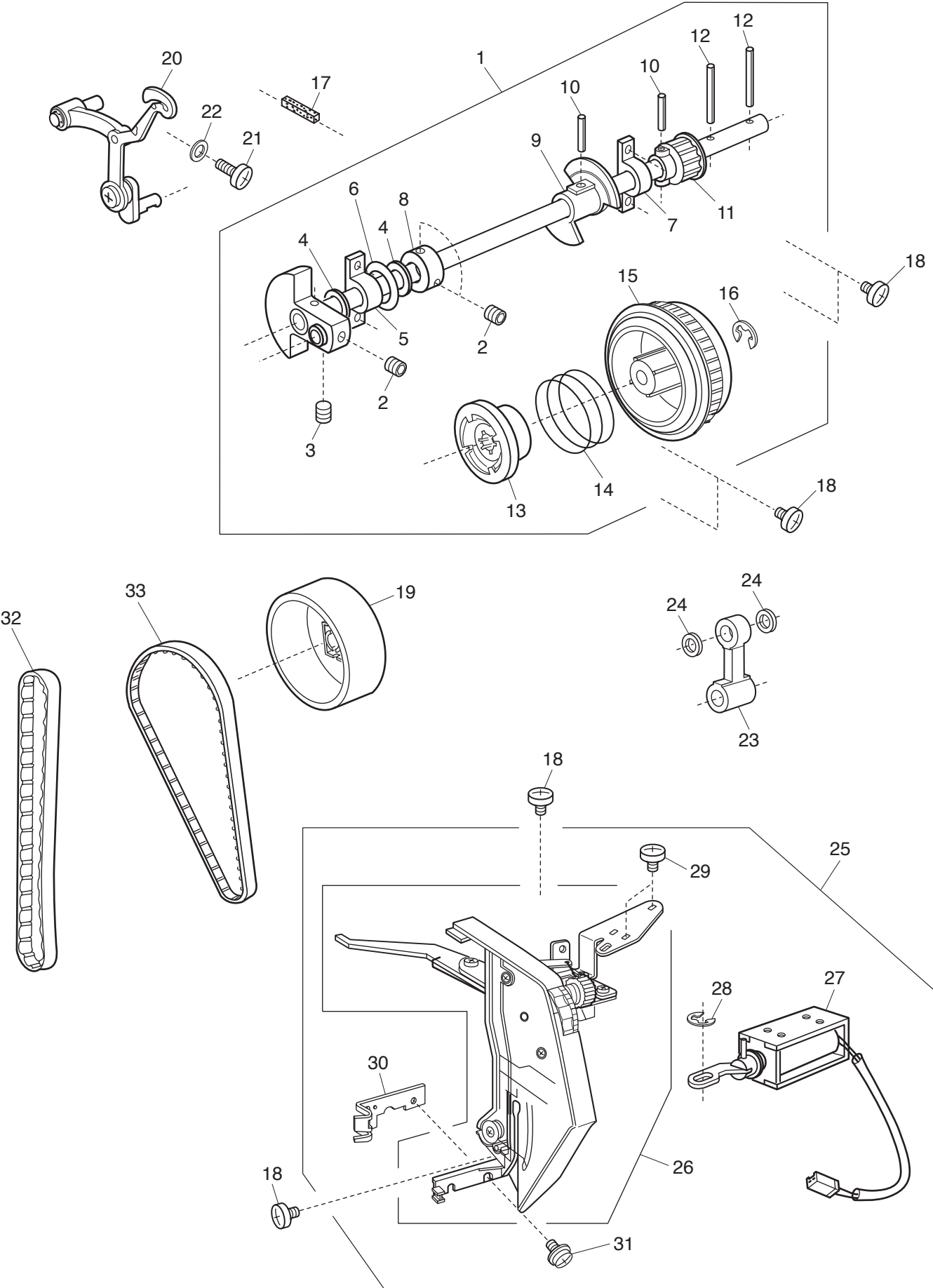

PARTS LIST

KEY NO.	PARTS NO.	DESCRIPTION
1	808601005	Upper shaft (unit)
2	000111201	Hexagonal socket screw 4x4
3	000112800	Hexagonal socket screw 4x6
4	000036201	Washer FT80
5	508120006	Shaft supporter plate
6	823110009	Felt
7	508054101	Shaft supporter plate
8	820166001	Lower shaft ring
9	808003001	Upper shaft shielding plate
10	000004200	Spring pin 3x18
11	508021006	Upper shaft gear
12	000024206	Spring pin 3x30
13	502064003	Clutch ring
14	661024007	Clutch spring
15	508055009	Belt wheel
16	000002806	Snap ring E-6
17	731312005	Felt
18	000081005	Setscrew 4x8
19	508056000	Handwheel
20	808648004	Thread take-up lever (unit)
21	000103509	Setscrew 4x10
22	000072302	Washer 4
23	808005003	Needle bar crank rod
24	000036005	Washer FT60
25	808616210	Thread tension (unit)
26	808501118	Thread tension
27	808604008	Solenoid (unit)
28	000002105	Snap ring E-3
29	000101105	Setscrew 3x4
30	809023000	Face plate spring set plate
31	000114709	Setscrew TP 3x6
32	808037004	Synchro belt S5M
33	808021005	Timing belt 120

PARTS LIST

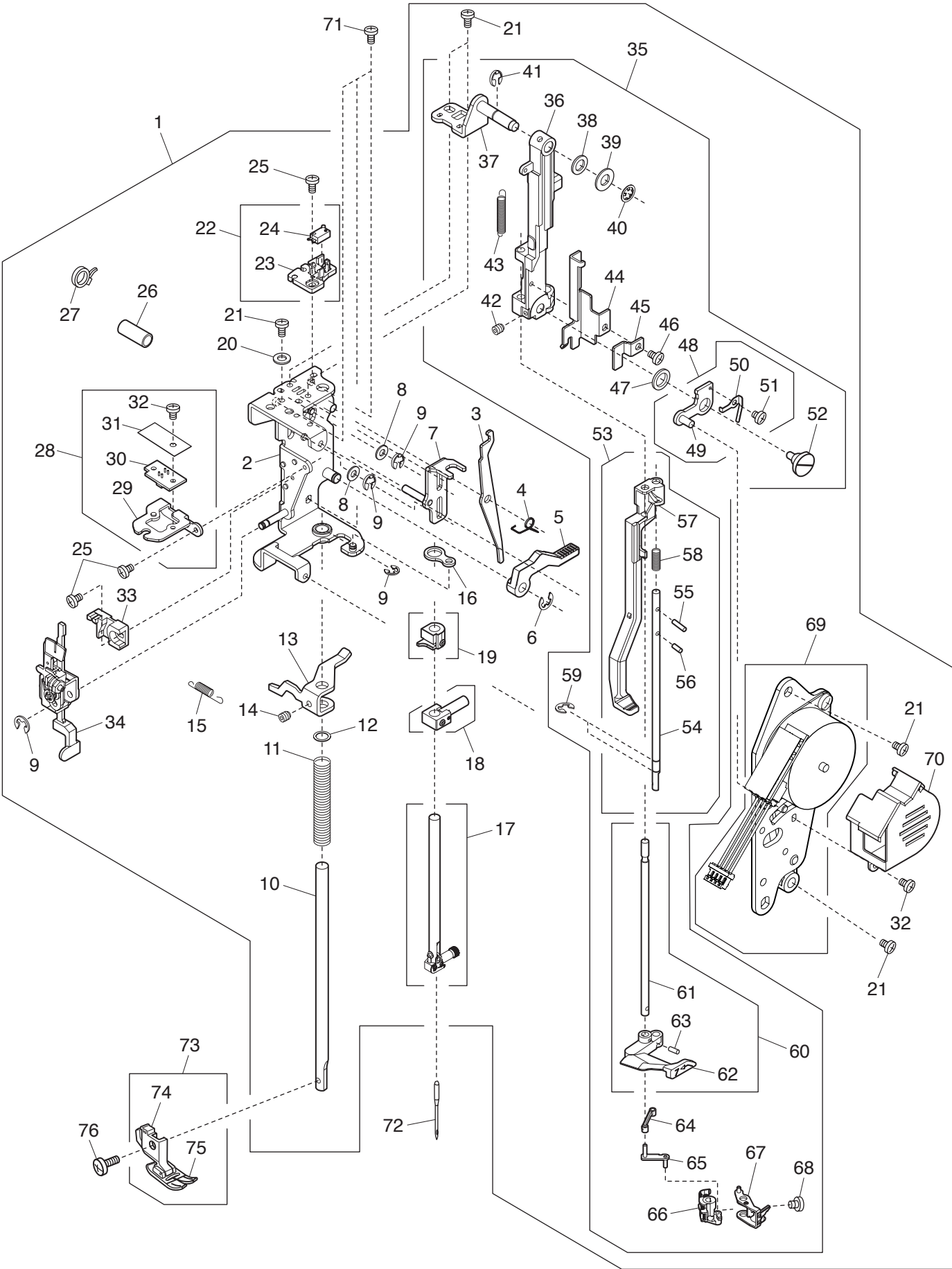

PARTS LIST

KEY NO.	PARTS NO.	DESCRIPTION
1	814610305	Presser bar base plate (unit)
2	814001008	Presser bar base plate
3	808007005	Thread tension release lever
4	503041007	Thread tension release spring
5	502024001	Presser foot lifter
6	000001609	Snap ring E-5
7	809128006	Presser bar spring adjusting plate
8	000072508	Washer 4
9	000002105	Snap ring E-3
10	827021107	Presser bar
11	830030006	Presser bar spring
12	826055004	Washer
13	809152009	Presser bar supporter
14	000111500	Hexagonal socket screw 4x8
15	844038018	Needle bar supporter spring
16	808010001	Supporter guide plate
17	814614000	Needle bar (unit)
18	809509005	Needle bar connecting stud (unit)
19	858540000	Rotation pin stopper (unit)
20	000072003	Washer 5
21	000101404	Setscrew 4x6
22	808611101	Presser foot lifter switch (unit)
23	808082004	Switch set plate
24	852510601	Micro switch (unit)
25	000103808	Setscrew 3x5
26	809046009	Tube
27	000053008	Cord binder
28	808606206	Buttonhole sensor (unit)
29	845002005	Sensor set plate
30	843502808	Printed circuit board E1 (unit)
31	845029008	Insulation paper
32	000101105	Setscrew 3x4
33	830057021	Buttonhole lever guide
34	808673008	Buttonhole lever (unit)
35	814611007	Needle bar supporter (unit)
36	814034103	Needle bar supporter
37	808009100	Supporter adjusting plate
38	673022002	Spring washer
39	000070609	Washer 6
40	000013903	Snap ring CS-5
41	000002507	Snap ring E-4
42	000111902	Hexagonal socket screw 3x4
43	814032008	Spring
44	814037003	Needle threader lever supporter 1
45	814038004	Needle threader lever supporter 2
46	000078320	Setscrew 3x6
47	863127003	Washer
48	861630008	Zigzag width rod (unit)
49	808015006	Zigzag width rod
50	827088009	Zigzag width rod spring
51	820373003	Setscrew 2x3
52	678084306	Eccentric pin
53	814612008	Threader shaft (unit)
54	814036002	Threader shaft
55	000265500	Guide pin E-2x12-CH
56	000265603	Guide pin E-2x6-CH
57	814035001	Threader lever
58	863128107	Threader lever spring
59	000001207	Snap ring E-2.5
60	814613009	Threader supporter shaft (unit)
61	814039005	Threader supporter shaft
62	814043105	Threader guide
63	000022204	Spring pin 2x6 (K)
64	858265008	Link plate 1
65	858266009	Link plate 2
66	862626026	Threader guide plate (unit)
67	862627108	Hook holder (unit)
68	000230403	Setscrew 2x5
69	808605803	Zigzag width motor (unit)
70	809019014	Motor cover
71	000081005	Setscrew 4x8
72	102408089	Needle
73	660509008	Presser foot (unit)
74	660806008	Presser foot holder (unit)
75	832523007	Zigzag foot (unit)
76	660106001	Setscrew

PARTS LIST

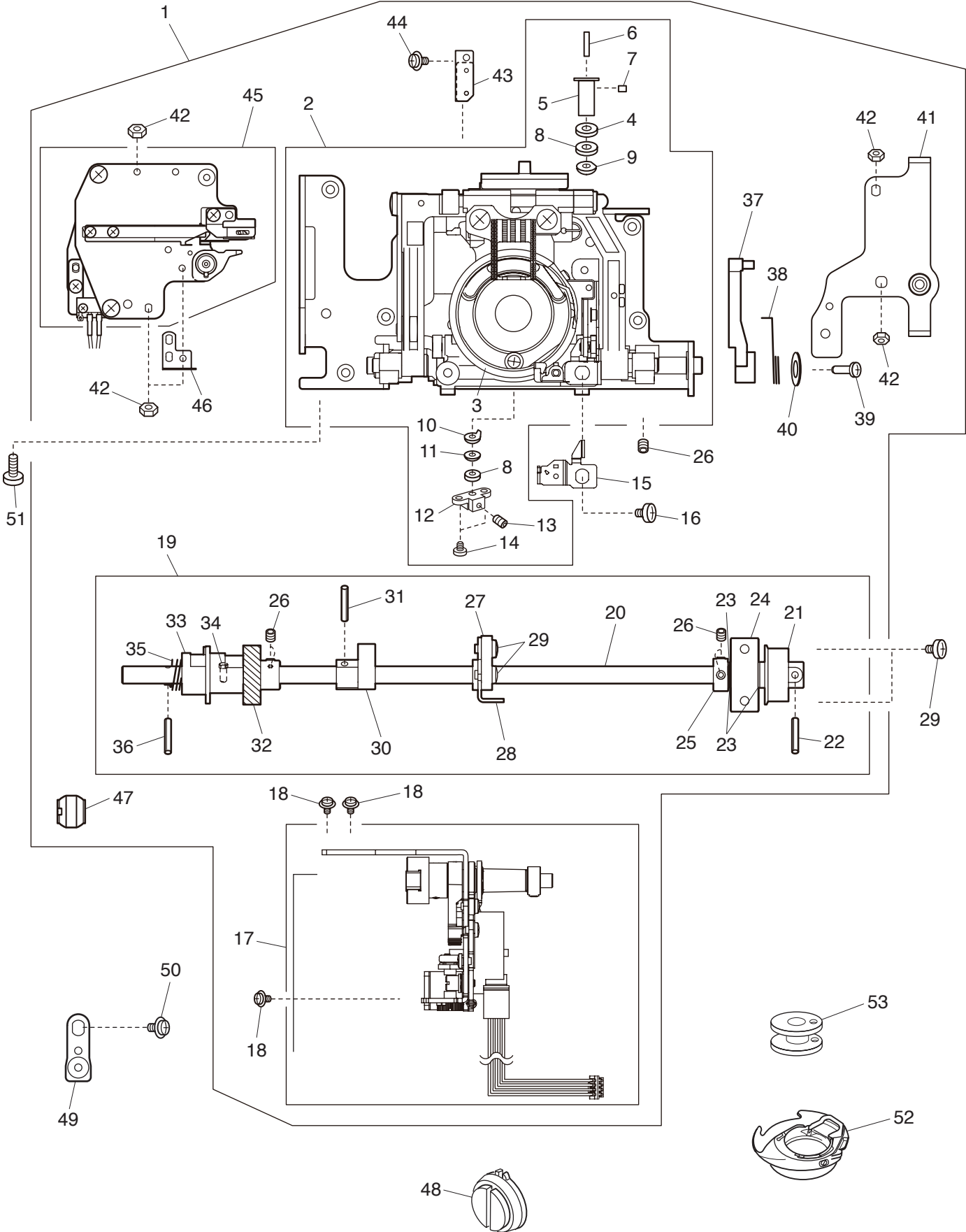

PARTS LIST

KEY NO.	PARTS NO.	DESCRIPTION
1	809620704	Hook race (whole unit)
2	809621015	Hook race (unit)
3	660536004	Hook body (unit)
4	508118001	Washer
5	820123006	Hook race shaft
6	820124007	Hook shaft oil wick (1)
7	820125008	Hook shaft oil wick (2)
8	000038409	Washer
9	508139008	Magnet set plate
10	627192001	Washer
11	625102008	Washer
12	508072002	Hook race shaft base
13	000111304	Hexagonal socket screw 5x5
14	000103705	Setscrew 4x5
15	627567104	Bobbin holder stopper (unit)
16	000101404	Setscrew 4x6
17	809607200	Feed regulator (unit)
18	000115205	Setscrew TP 4x6
19	809602009	Lower shaft (unit)
20	808027207	Lower shaft
21	508021006	Upper shaft gear
22	000004200	Spring pin 3x18
23	000038502	Washer
24	508054008	Shaft supporter plate
25	820166001	Lower shaft ring
26	000111201	Hexagonal socket screw 4x4
27	809017001	Lower shaft supporter
28	809016000	Lower shaft supporter plate
29	000081005	Setscrew 4x8
30	809014008	Feed cam
31	000005407	Spring pin 3x12
32	808137005	Lower shaft gear
33	846103000	Feed lifting cam
34	820161006	Feed lifting pin
35	808075004	Feed lifting cam spring
36	000022802	Spring pin 2x12
37	809013007	Feed fork
38	809015009	Feed fork spring
39	820172000	Pin
40	000071105	Washer 5
41	809064003	Needle plate set plate (right)
42	000063104	Nut 3-2-5.5
43	825515004	Feed base plate (unit)
44	825237009	Setscrew
45	809623305	Thread cutter (unit)
46	808105107	Slide position adjusting plate
47	732034003	Lower shaft bushing
48	809053009	Feed balancing dial 2
49	809042005	Lower shaft bushing set plate
50	000115607	Setscrew TP 4x8
51	000101703	Setscrew 4x12
52	858570009	Bobbin holder (unit)
53	102261103	Bobbin

PARTS LIST

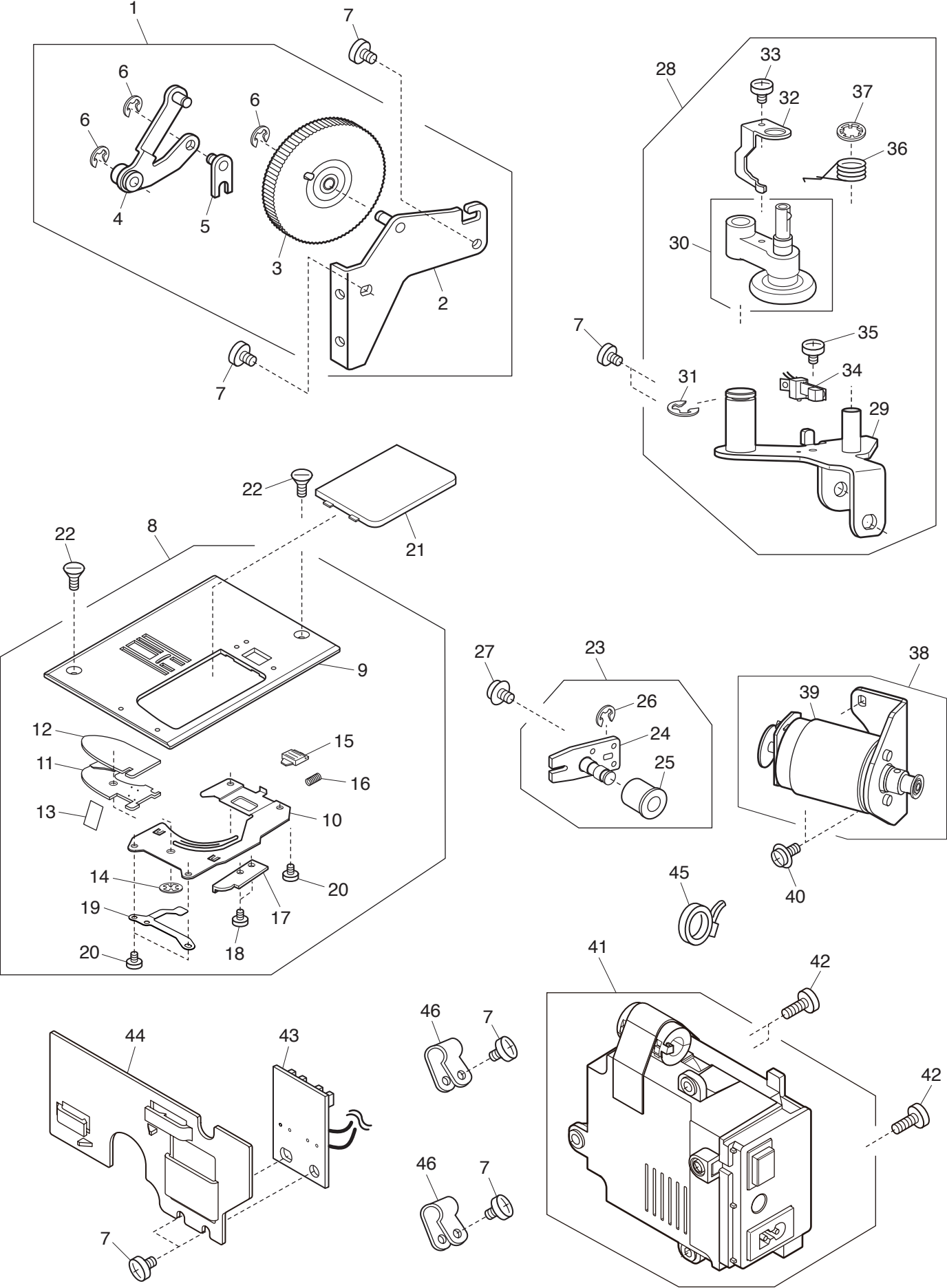

PARTS LIST

KEY NO.	PARTS NO.	DESCRIPTION
1	809608005	Presser foot pressure adjustment (unit)
2	809018002	Presser foot pressure adjusting set plate
3	808078203	Presser foot pressure dial
4	808079008	Adjusting arm 1
5	808080002	Adjusting arm 2
6	000002105	Snap ring E-3
7	000081005	Setscrew 4x8
8	809616017	Needle plate (unit)
9	809132003	Needle plate
10	809133004	Hook cover plate supporter
11	809134005	Hook cover plate supporter base
12	809135006	Guide holder
13	809137008	Cutter
14	000014306	Snap ring CS-3
15	825016000	Hook cover plate release button
16	825017001	Spring
17	809050006	Rotation stopper
18	000163703	Setscrew 2x3.5
19	809184000	Spring
20	820374004	Setscrew 2x2.3
21	809136100	Hook cover plate
22	681009101	Setscrew
23	808614001	Idler (unit)
24	808038005	Idler set plate
25	625217100	Idler
26	000002806	Snap ring E-6
27	000115607	Setscrew TP 4x8
28	808615002	Bobbin winder (unit)
29	808039006	Bobbin winder set plate
30	508507001	Bobbin winder arm (unit)
31	000001609	Snap ring E-5
32	508111004	Clutch lever
33	000120203	Setscrew 3x8 (B)
34	856512100	Switch (unit)
35	000081706	Setscrew 2.5x5
36	808040000	Spring
37	000013903	Snap ring CS-5
38	808617004	DC motor (unit)
39	808502005	DC motor
40	000115700	Setscrew TP 4x10
41	808668402	Switching regulator (unit) (with Auto-off-timer) *must be used with:809405066 Printed circuit board A (unit)
42	000103509	Setscrew 4x10
43	808504007	Printed circuit board P (unit)
44	808181004	Cord guide
45	000053008	Cord binder
46	000188405	Nylon clip ACC-2

PARTS LIST

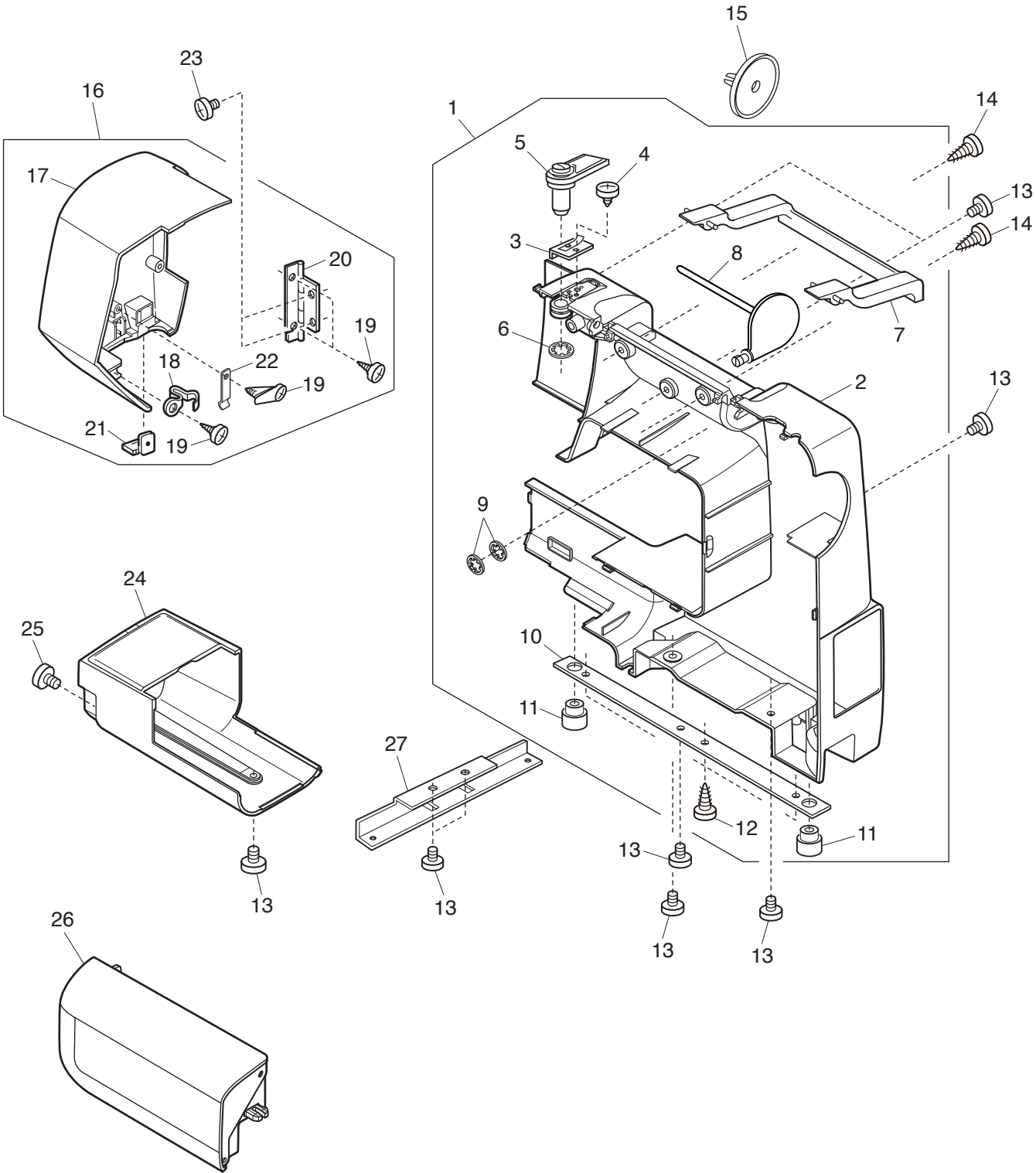

PARTS LIST

KEY NO.	PARTS NO.	DESCRIPTION
1	809604322	Rear cover (unit)
2	809025A06	Rear cover
3	827503108	Top cover thread guide (unit)
4	000162001	Setscrew 2.6x5 (B)
5	650503322	Thread guide (unit)
6	000014409	Snap ring CS-8
7	809026003	Carrying handle
8	809027004	Spool pin
9	000013800	Snap ring CS-6
10	809028005	Arm leg rear
11	735003002	Bed rubber cushion
12	000198604	Setscrew 4x14 (B)
13	000081005	Setscrew 4x8
14	000160401	Setscrew 4x16 (B)
15	822020503	Spool holder
16	809656111	Face plate (unit)
17	809186A01	Face plate
18	731067002	Face plate spring
19	000161206	Setscrew 3x10 (B)
20	851503103	Face plate hinge (unit)
21	840602006	Thread cutter (unit)
22	859233000	Magnifier fixing plate
23	000081119	Setscrew 4x6
24	808061007	Free arm cover
25	000101404	Setscrew 4x6
26	808508001	Extension table (unit)
27	809024001	Arm sole set plate

PARTS LIST

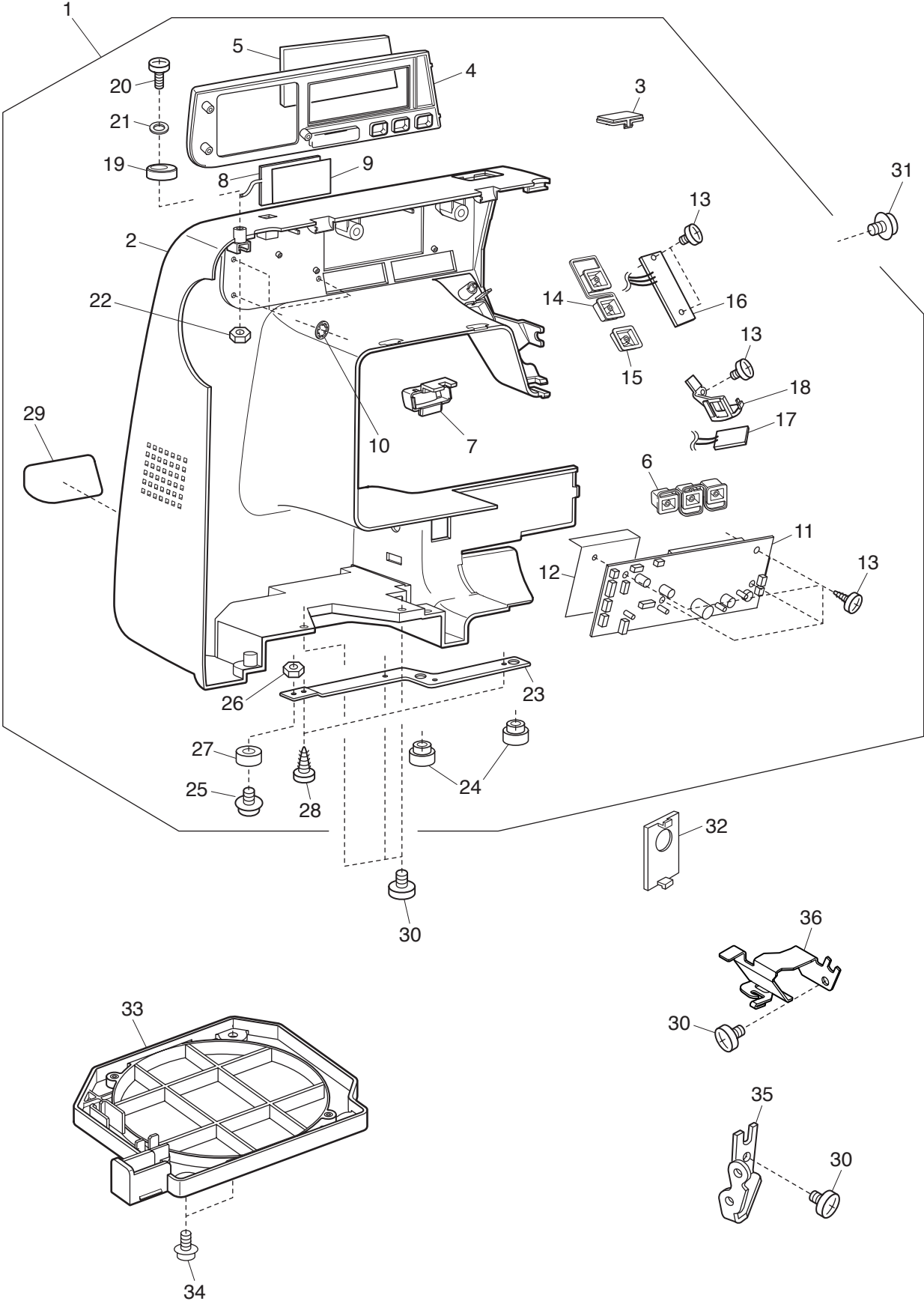

PARTS LIST

KEY NO.	PARTS NO.	DESCRIPTION
1	809605057	Front cover (unit)
2	809030A04	Front cover
3	808103002	Front cover lid
4	809031B01	Ornamental panel 1
5	809032A04	Ornamental panel 2
6	809033A01	Button 1
7	809036305	Slide volume
8	809501007	Touch panel (unit)
9	809037A05	Touch panel sheet
10	000014306	Snap ring CS-3
11	809405066	Printed circuit board A (unit)
12	809048001	Flame retardant insulating paper
13	000120203	Setscrew 3x8 (B)
14	809034A02	Button 2
15	809035A03	Start/stop button
16	809502008	Printed circuit board F (unit)
17	812502101	Printed circuit board L (unit)
18	808118000	Lamp holder 2
19	735016307	Bobbin winder stopper
20	000101828	Setscrew 4x16
21	000071013	Washer 4
22	000061205	Nut 4-3-7
23	809038008	Arm sole front
24	735003002	Bed rubber cushion
25	000114802	Setscrew TP 4x12
26	000160102	Adjustable lock nut 4
27	639005003	Rubber foot
28	000198604	Setscrew 4x14 (B)
29	101636A01	Emblem
30	000081005	Setscrew 4x8
31	000115205	Setscrew TP 4x6
32	809039009	Cap
33	808059301	Bed cover
34	000149312	Setscrew 3x8
35	639080002	Front cover set plate
36	809188004	Arm thread guide

PARTS LIST

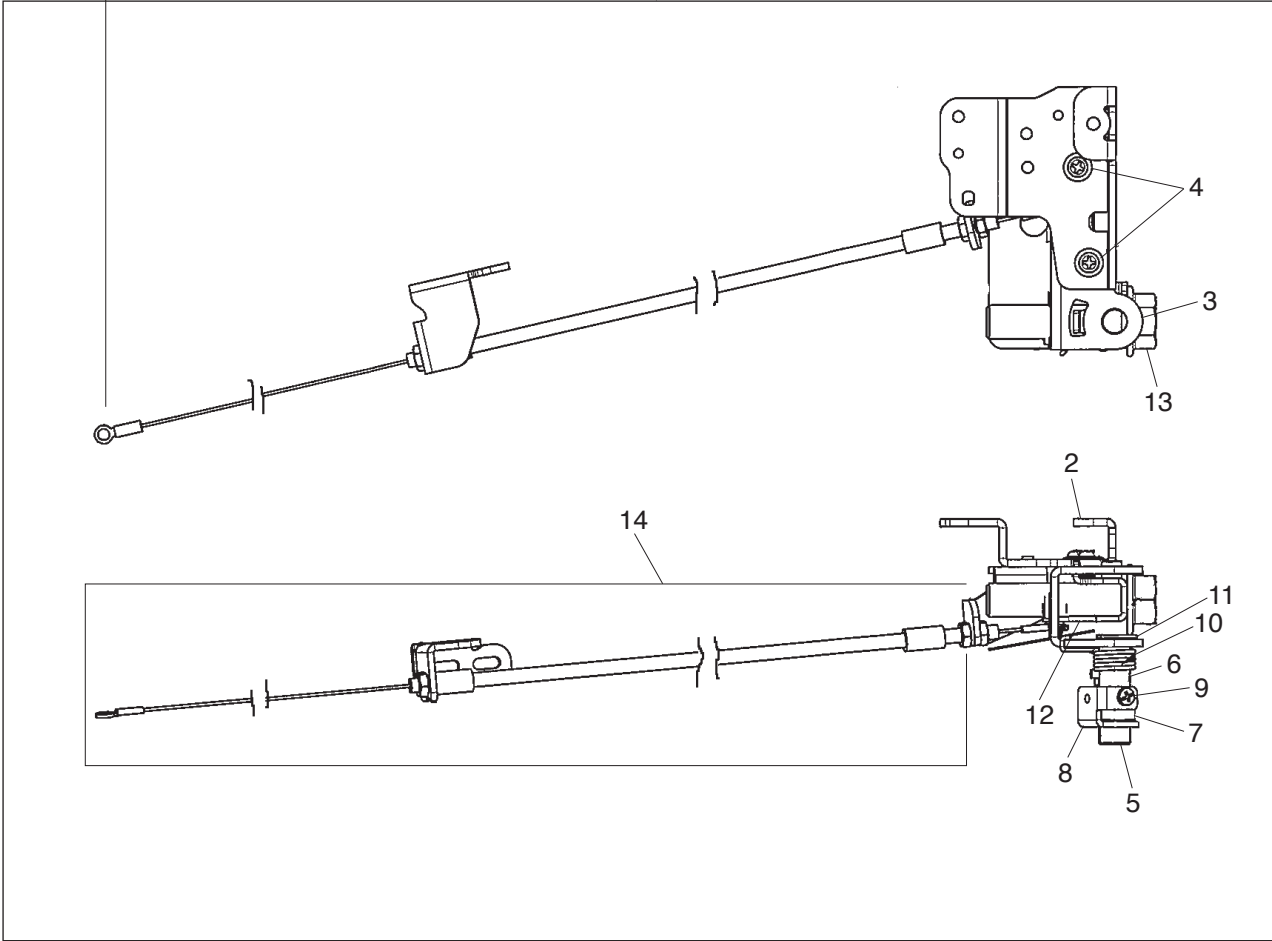
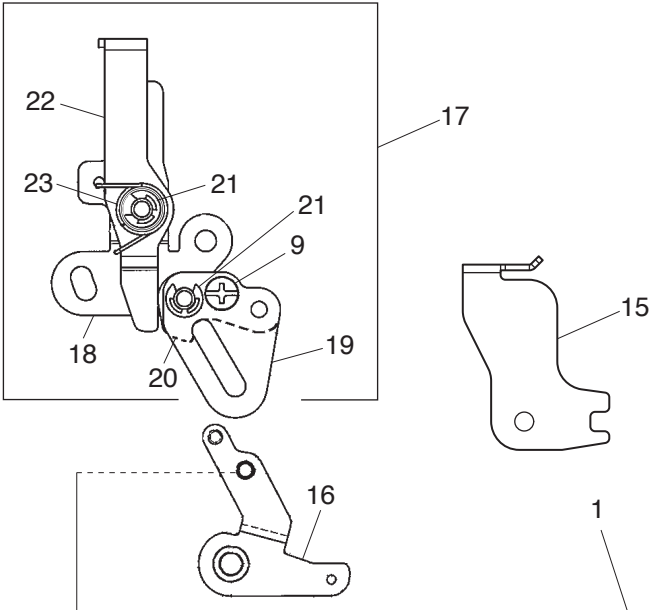

PARTS LIST

KEY NO.	PARTS NO.	DESCRIPTION
1	809643208	Knee lift shaft (unit)
2	809154001	Knee lifter base 1
3	809155002	Knee lifter base 2
4	000115205	Setscrew TP 4x6
5	809156003	Knee lift shaft
6	000004107	Spring pin 3x14
7	846297002	Stopper
8	861072006	Stopper plate
9	000101105	Setscrew 3x4
10	809157004	Knee lift shaft spring
11	000030205	Snap ring E-8
12	809158005	Knee lift link plate
13	000138503	Bolt 5x12
14	809647006	Wire (unit)
15	809162002	Wire guide 2
16	809163003	Knee lift arm
17	809644003	Thread tension release link (unit)
18	809166006	Thread tension release base
19	809167007	Thread release cam guide
20	809168008	Thread release cam
21	000002105	Snap ring E-3
22	809169009	Thread tension release link
23	809170003	Thread release link spring

PARTS LIST

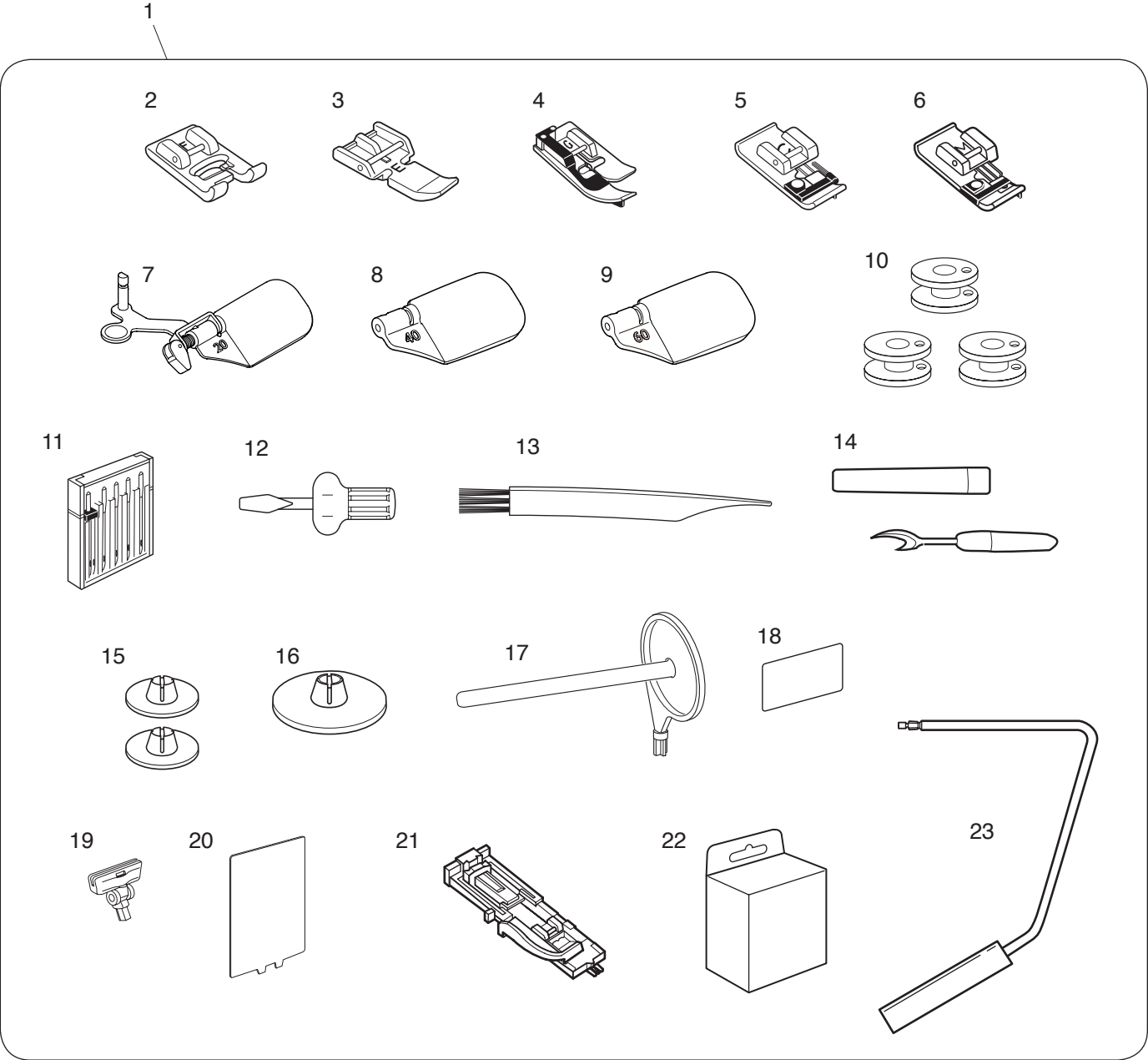

24 (Continental Europe)

24 (UK)

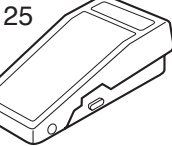
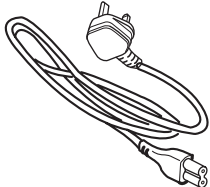
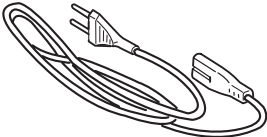

29

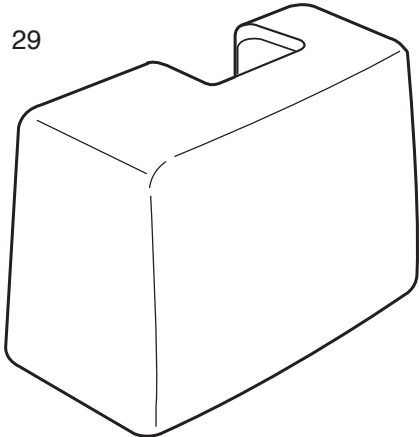

26



27

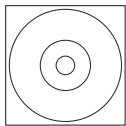

28

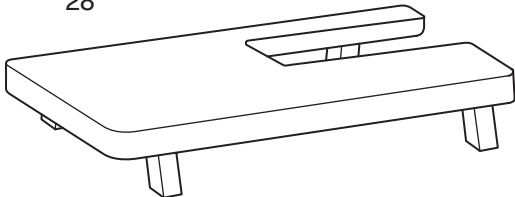

PARTS LIST

KEY NO.	PARTS NO.	DESCRIPTION
1	809870365	Standard accessories (unit)
2	822804118	Satin foot (F) (unit)
3	808852003	Zipper foot (E) (unit)
4	825817009	Blind hem foot (G) (unit)
5	822801001	Overedge foot (C) (unit)
6	822808008	Overcast foot (M) (unit)
7	858415005	Optic magnifier (20)
8	858415500	Optic magnifier (40)
9	858415603	Optic magnifier (60)
10	102261103	Bobbin
11	820827007	Assorted needle set (unit)
12	820832005	Screwdriver
13	802424004	Lint brush
14	647808009	Seam ripper (buttonhole opener)
15	822019509	Spool holder (small)
16	822020503	Spool holder (large)
17	809041004	Spool pin
18	809806005	Caution card (included in instruction book)
19	809809008	Stitch chart holder
20	809801A10	Stitch chart
21	753801004	Buttonhole foot (R) (unit)
22	200100007	Quilting attachment (unit)
23	846811008	Knee lifter
24	830335004	Power supply cord (Continental Europe)
	830377008	Power supply cord (UK)
25	C-1036	Foot control
26	809851186	Instruction book (Dutch)
	809851197	Instruction book (German)
	809851201	Instruction book (French)
	809851153	Instruction book (English)
27	809862009	Instructional DVD
28	808401003	Large extension table (unit)
29	404701404	Hard cover